



REQUEST FOR PROPOSAL (RFP)

Leon County School Board
Purchasing Department

Release Date: July 14, 2022
RFP No.: **473-2022**
RFP Title: **Fencing Materials and Installation District Wide**
Contact: Nancy Scott / scottn@leonschools.net
Phone: 850-488-1206

The Leon County Board ("School Board") solicits your company to submit a proposal on the above referenced goods or services. All terms, specifications and conditions set forth in this request are incorporated by this reference into your response. This proposal must be submitted to The Leon County School Board, Purchasing Department, 3397 W. Tharpe St, Tallahassee, Florida 32303, no later than **2:00 p.m.** local time on **August 10, 2021** and plainly marked **RFP No. 473-2022**. Proposals are due and will be opened at this time.

REQUIRED SUBMITTAL CHECKLIST - For each item below, insert bidder Authorized Agent initials verifying that forms are accurately completed, signed by an officer of the business and returned with the proposal. Failure to provide all requested documents may result in your proposal being declared non-responsive.

Bidder should submit one (1) original, five (5) copies and one (1) electronic copy (USB drive)

- Bidder Acknowledgement Form
- Dispute Contact – pg. 6, item 23
- Proposal Response – pg. 23, Section IX
- Cost Proposal Form – pg. 25-28
- Conflict Of Interest Certificate (Exhibit A)
- Vendor Application Forms (Exhibit B)
- E-Verify Affidavit (Exhibit C)
- Customer Reference (Exhibit D)
- Vendor Questionnaire (Exhibit E)
- Drug Free Workplace Certification (Exhibit F)
- Certification Regarding Debarment (Exhibit G)
- Sworn Statement / Jessica Lunsford Act (Exhibit H)

**THE FOLLOWING MUST BE COMPLETED, SIGNED AND RETURNED AS PART OF YOUR PROPOSAL.
PROPOSALS WILL NOT BE ACCEPTED WITHOUT THIS FORM, SIGNED BY AN AUTHORIZED AGENT OF THE BIDDER.**

Authorized Representative's Name/Title	Authorized Representative's Signature	Date
Company's Name	Telephone Number	FAX Number
Address	City	State Zip Code
Area Representative	Telephone Number	FAX Number
Federal Employer's Identification Number (FEIN)	Email	

Signature of Authorized Officer/Agent: _____ Typed or Printed Name _____

(Proposal must be signed by an officer or employee having authority to legally bind the bidder)

I certify that I have not divulged, discussed, or compared this proposal with any other Proposers and have not colluded with any other proposer in the preparation of this proposal in order to gain an unfair advantage in the award of this contract. I acknowledge that all information contained herein is part of the public domain as defined in the Public Records Act, Chapter 119, F.S.

By signing and submitting this proposal I certify that I am authorized to sign this proposal for this vendor and further certify unconditional acceptance of the contents of this RFP, all Attachments, Worksheets, Appendices, Supplemental Materials, and the contents of any Addendum released hereto.

NO RESPONSE – I HEREBY SUBMIT THIS AS A "NO RESPONSE" FOR THE REASON(S) CHECKED BELOW

- | | | |
|--|--|--|
| <input type="checkbox"/> Remove our name from this bid list only | <input type="checkbox"/> Insufficient time to respond to the RFP | <input type="checkbox"/> Could not meet insurance requirements |
| <input type="checkbox"/> Our product schedule would not permit us to perform | <input type="checkbox"/> We do not offer the product or service requested. | <input type="checkbox"/> Could not meet specifications |
| <input type="checkbox"/> Keep our company on bid list for future bids | <input type="checkbox"/> Other _____ | |

TABLE OF CONTENTS

	Page
Bidder Identification Label (affixed to submittal)	3
Section I: General Terms And Conditions	4
Dispute Resolution Contact	6
Section II: Licensure, Insurance and Liability	7
Section III: Goods and Services	8
Section IV: Bidder Requirements	9
Section V: Scope Of Work and Specifications	11
Section VI: Technical Specifications - Aluminum Security Fences and Gates	15
Section VII: Technical Specifications - PVC Coated Steel Chain Link Fence Fabric and Gates	17
Section VIII: Technical Specifications - Chain Link Fences and Gates	20
Section XI: Questionnaire and Response	22
Cost Proposal Form	24-27
Conflict Of Interest Certificate	EXHIBIT A
Application for Vendor Forms	EXHIBIT B
E-Verify	EXHIBIT C
Customer Reference Form	EXHIBIT D
Vendor Questionnaire	EXHIBIT E
Drug Free Workplace Certification	EXHIBIT F
Certification Regarding Debarment	EXHIBIT G
Sworn Statement / Jessica Lunsford Act	EXHIBIT H
Affidavit For Claiming Local Purchasing Preference	EXHIBIT I
Indemnification and Insurance Requirements	EXHIBIT J
Work Order Form	EXHIBIT K
Address/Phone Listing of District School Sites	EXHIBIT L
Listing of Additional District Facilities	EXHIBIT M
Drawings (4 Pages)	EXHIBIT N

BID IDENTIFICATION LABEL

NOTICE TO ALL BIDDERS: A label has been provided to properly identify your RFP. Place the proposal in a sealed envelope, type the name and address of the bidder on the label and affix the label to the front of the envelope.

The School Board Purchasing office is open from 8:00 a.m. - 5:00 p.m. Monday through Friday. If you are hand delivering a proposal, a Purchasing representative will be available to time/date stamp your submittal during these hours.

Cut out the label below and attach it to your envelope.

Sealed Bid – DO NOT OPEN	Sealed Bid – DO NOT OPEN
RFP Title:	Fencing Materials and Installation District Wide
RFP No.:	473-2021
RFP Due:	August 10, 2021
From:	_____
Address:	_____ _____
Deliver To:	Leon County Schools Purchasing Department 3397 West Tharpe Street Tallahassee, Florida 32303
Sealed Bid – DO NOT OPEN	Sealed Bid – DO NOT OPEN

I. GENERAL TERMS AND CONDITIONS

1. INTRODUCTION: The Leon County School Board (the Board) is soliciting proposals for the purpose of identifying qualified fencing contractors and establishing firm pricing to provide materials and labor for the installation of security, chain link, PVC coated, and ornamental fencing and to perform repairs, maintenance and other minor fencing projects on an as needed basis district wide.

2. SCHOOL BOARD CONTACT: All questions for additional information regarding this RFP must be directed to the designated Purchasing Agent noted on the title page.

All contact and requests for clarifications should be submitted via e-mail to: forbest@leonschools.net no later than **July 27, 2021**. Responses will be distributed no later than **July 28, 2021**.

Prospective bidders shall not contact any member of the Leon County School Board, Superintendent or staff regarding this RFP prior to posting of the final tabulation and award recommendation on the website and in the Purchasing Office. Any such contact shall be cause for rejection of your proposal.

3. DEFINITIONS: The term "Bidder" as used within this Request for Proposal (RFP) refers to the person, company or organization responding to this RFP. The Bidder is responsible for understanding and complying with the terms and conditions herein. The term "School Board" refers to the School Board of Leon County, Florida.

4. BIDDER'S RESPONSIBILITY: It is the responsibility of the bidder to obtain all pages of the RFP package and all attachments thereto, together with any addenda to the RFP package that may be issued prior to the RFP due date. RFP package and addenda as well as general information can be found at www.leonschools.net/Page/4411.

Before submitting their proposal, each bidder is required to carefully examine the RFP specifications and to completely familiarize themselves with all of the terms and conditions that are contained within this request. Ignorance on the part of the bidder will in no way relieve them of any of the obligations and responsibilities which are a part of this RFP.

5. AWARD: In the event of contract award, this contract shall be awarded to the responsible and responsive bidder(s) whose proposal is determined to be the most advantageous to the District, taking into consideration price and other requirements as set forth in the RFP. Due to the potential for the existence of multiple overlapping projects at any given time, it is in the best interest of the District to award this contract to multiple vendors, creating a list of pre-qualified contractors meeting all specifications listed herein and offering the best value to the Board. **Low cost proposal is but one of the evaluation parameters and does not guarantee contract award.** The awarded contractor(s) understands and agrees that the contract shall not be construed as an exclusive agreement and further agrees that the District may secure identical and/or similar services or products from other sources at any time in conjunction with or in replacement of the contractor's services.

Once proposals are evaluated, the Purchasing Department will post a Notice of Intent to Award by electronic posting at www.leonschools.net/Page/4411 on or about **August 16, 2021** for a period of 72 hours or three business days, whichever is later. Failure to file a protest within the time prescribed in section 120.57 (3) , Florida Statutes, or failure to post the bond or other security required by law within the time allowed for filing a bond shall constitute a waiver of proceedings under chapter 120, Florida Statutes.

It is anticipated that a recommendation for award will be presented to the School Board for consideration at its **August 24, 2021** meeting.

6. ORIGINAL AND RENEWAL TERM: Unless otherwise indicated in the detailed specifications the award resulting from this RFP will begin after School Board approval, **on or about August 25, 2021 through June 30, 2023**. The award resulting from this RFP (or any portion thereof) has the option of being renewed for three (3) additional one (1) year periods, or

extended for a period up to 180 days beyond the current term, including the final term, upon mutual agreement of both parties, under the same terms and conditions as the original award. The School Board, through its Purchasing Department, will, if considering a renewal or extension, request a letter of intent to renew or extend from one or more awardees, prior to the end of the current contract period. The awardees will be notified when the recommendation has been acted upon by The School Board. The Bidder agrees to these conditions by signing its proposal.

7. RESERVATION FOR REJECTION OR AWARD: The School Board reserves the right to reject any or all proposals, to waive irregularities or technicalities, and to request rebids. The School Board reserves the right to award on an individual item basis, any combination of items, total low proposal or, if an alternate proposal is accepted, on such terms as are specified for the alternate proposal, whichever manner is in the best interest of the School Board.

8. CONTRACT: The submission of your proposal constitutes a firm offer by the bidder. Upon acceptance by the School Board, the Purchasing Department will issue a notice of award and purchase order(s) for any supplies, equipment and/or services as a result of this RFP. The RFP and the corresponding purchase order(s) will constitute the complete agreement between the successful bidder and the School Board. Unless otherwise stipulated in the RFP documents or agreed to in writing by both parties, no other contract documents shall be issued or accepted.

9. FIRM OFFER: Any proposal may be withdrawn until the date and time set for the opening of the RFP. Any proposal not so withdrawn shall constitute an irrevocable offer to provide the School Board the services/products set forth in this RFP. Such offer shall be held open for a period of sixty (60) days from RFP opening date or until one of the proposals has been awarded by the School Board.

10. CONFIDENTIALITY: Bidders shall be aware that all proposals provided with a RFP are subject to public disclosure and will not be afforded confidentiality with the exception of "sealed" financial statements.

11. PREQUALIFICATION OF CONTRACTORS FOR EDUCATIONAL FACILITIES CONSTRUCTION: In accordance with State Requirements for Educational Facilities (S.R.E.F.), 2014, Chapter 4, Section 4.1, Prequalification of Contractors for Educational Facilities Construction: **ONLY** contractors who hold a current Leon County School Board - Prequalification Certificate may submit their qualifications.

On April 14, 2015, the Leon County School Board revised and adopted [Policy 6334](#), *Prequalification of Contractors for Educational Facilities & Construction*. The School Board will prequalify contractors for a one-year period pursuant to the criteria set forth in Florida Statutes 1013.46, and State Requirements for Educational Facilities, Chapter 4, Section 4.1 (1). Certificates will be valid for one year from the date of School Board approval and must be renewed annually. Submittals for work from firms not prequalified at the time of submittal will be deemed nonresponsive and will not be considered.

Instructions for completion and submission of the Qualifications Statement may be obtained on our website at <http://www.leonschools.net/Page/4233> or request assistance from Leon County School Board, Facilities and Construction, 3420 West Tharpe Street, Suite 100, Tallahassee, Florida 32303, 850- 617-5900.

12. PUBLIC RECORDS LAW: Pursuant to Florida Statutes Chapter 119.071(1), proposals received as a result of this RFP will not become public record until thirty (30) days after the date of opening or until posting of a recommendation for award, whichever occurs first. Thereafter, all proposal documents or other materials submitted by all bidders in response to this RFP will be open for inspection by any person and in accordance with Chapter 119, Florida Statutes. To the extent a Bidder asserts any portion of its proposal is exempt or confidential from disclosure under Florida's public records, the burden shall be on the bidder to obtain a protective order from a jurisdictional court protecting

such information from disclosure under Florida's public records laws and also timely provide a certified copy of such protective order to the School Board prior to the School Board's release of such information into the public domain.

13. USE OF OTHER CONTRACTS: The School Board reserve the right to utilize any other District contract, any State of Florida Contract, any contract awarded by any other City or County governmental agencies, any other School Board, any other Community College/State University system, any cooperative bid agreement, or to directly negotiate/purchase per School Board policy and/or State Board Rule 6A-1.012(6) in lieu of any offer received or award made as a result of this RFP, if it is in the best interest to do so. The School Board also reserves the right to separately bid any single order or to purchase any item on this RFP if it is in its best interest to do so.

14. JOINT-BIDDING, COOPERATIVE PURCHASING AGREEMENT: All bidders submitting a response to this RFP agree that such response also constitutes a proposal to all State Agencies and Political Subdivisions of the State of Florida under the same conditions, for the same prices and for the same effective period as this RFP, should the bidder(s) deem it in the best interest of their business to do so. This agreement in no way restricts or interferes with any state agency or political subdivision of the State of Florida to rebid any or all items.

State agencies wishing to make purchases from this agreement are required to follow the provisions of s. 287.042(16) (a), F.S. This statute requires the Department of Management Services to determine that the requestor's use of the contract is cost-effective and in the best interest of the State.

Pursuant to their own governing laws, and subject to the agreement of the Contractor, other entities may be permitted to make purchases at the terms and conditions contained herein. Non-Customer purchases are independent of the agreement between Customer and Contractor, and Customer shall not be a party to any transaction between the Contractor and any other purchaser.

The purchasing agreements and state term contracts available under s. 287.056 have been reviewed.

15. RFP PREPARATION COSTS: Neither the School Board nor its representatives shall be liable for any expenses incurred in connection with the preparation of a response to this RFP.

16. BID BONDS AND PERFORMANCE BONDS: Bid bonds, when required shall be submitted with the bid in the amount specified in the detailed specifications. Bid bonds will be returned to unsuccessful bidders. After Acceptance of a bid, the School Board will notify the successful bidder to submit a recorded payment and performance bond in the amount specified in the detailed specifications.

17. RFP OPENING AND FORM: Proposal openings will be public on the date and time specified on the Bidder's Acknowledgement Form. All Proposals received after the time indicated will be rejected as non-responsive and returned unopened to sender. Proposals by Email, fax, telegram, or verbally by telephone or in person will not be accepted. The School Board is not responsible for lost or late delivery of proposals by the U.S. Postal Service or other delivery services used by the Bidder.

18. CLARIFICATIONS AND INTERPRETATIONS: The School Board reserves the right to allow for clarification of questionable entries, and for the bidder to withdraw items with obvious mistakes. In the event of a conflict between the General Bid Terms and Conditions and any Special terms and Conditions attached hereto, the Special Terms and Conditions shall have precedence. Any questions concerning terms, conditions or specifications will be directed to the designated Purchasing Agent referenced on the RFP Acknowledgement. Any ambiguities or inconsistencies shall be brought to the attention of the designated Purchasing Agent in writing at least seven workdays prior to the opening date of the proposal. Failure to do so, on the part of the bidder will

constitute an acceptance by the bidder of consequent decision. An addendum to the RFP shall be issued and posted for those interpretations that may affect the eventual outcome of this RFP. It is the bidder's responsibility to assure the receipt of all addendum issued. No person is authorized to give oral interpretations of, or make oral changes to the RFP. Therefore oral statements given before the RFP opening date will not be binding. The School Board will consider no interpretations binding unless provided for by issuance of an addendum. Addenda will be made available at least five workdays prior to the opening date at <http://www.leonschools.net/Domain/195>. The bidder shall acknowledge receipt of all addenda by signing and enclosing said addenda with their proposal.

19. EVALUATION CRITERIA: Primary factors used to decide the award hereunder will be price, availability and responsiveness. Other factors that may be used in the evaluation of this RFP will be: (1.) administrative costs incurred by the School Board in association with the discharge of any subsequent award; (2.) alternative payment terms; (3.) Bidder's past performance. The School Board reserves the right to evaluate by lot, by partial lot, or by item, and to accept or reject any proposal in its entirety or in part, and to waive minor irregularities if the proposal is otherwise valid. In the event of a price extension error, the unit price will be accepted as correct. The School Board has sole discretion in determining testing and evaluation methods.

20. DEFAULT: In the event that the awarded bidder should breach this contract, the School Board reserves the right to seek all remedies in law and/or in equity.

21. FUNDING OUT/CANCELATION OR TERMINATION WITH OR WITHOUT CAUSE:

A. WITH CAUSE: In the event any of the provisions of the Contract are violated by the bidder, the Superintendent or designee shall give written notice to the bidder stating the deficiencies and unless the deficiencies are corrected within ten days, recommendation will be made to the School Board or its designee for immediate cancellation. Upon cancellation, hereunder the School Board may pursue any and all legal remedies as provided herein and by law. In the event that it is subsequently determined that a cancellation under this paragraph was incorrect, the termination shall be converted to a termination for convenience pursuant to the next paragraph.

B. WITHOUT CAUSE: The School Board or its designee reserves the right to terminate any contract resulting from this RFP at any time and for no reason whatsoever, upon giving 30 days prior written notice to the bidder. If the Contract should be terminated for convenience as provided herein, the School Board shall be relieved of all obligations under said Contract. The School Board or its designee shall only be required to pay to the successful bidder that amount of the Contract actually performed to the date of termination.

C. FUNDING OUT: Florida School Laws prohibit the School Board or its designee from creating obligations on anticipation of budgeted revenues from one fiscal year to another without year-to-year extension provisions in the contracts. It is necessary that fiscal funding out provisions be included in all RFPs in which the terms are for periods of longer than one year. Therefore, the following funding out provisions are an integral part of this RFP and must be agreed to by all bidders:

The School Board or its designee may, during the contract period, terminate or discontinue the items covered in this RFP for lack of appropriated funds upon the same terms and conditions. Such prior written notice will state:

1. That the lack of appropriated funds is the reason for termination, and

2. School Board agrees not to replace the equipment or services being terminated with equipment and services with functions similar to those performed by the equipment covered in this RFP from another vendor in the succeeding funding period.

"This written notification will thereafter release the School Board of Leon County, Florida of all further obligations in any way related to such equipment covered herein".

22. TIE BID: According to FS 287.087, tie bid preference shall be awarded to Bidders with Drug Free Work Place programs. Whenever two or more are equal with regard to price, quality, and service, a proposal received from a business that certifies that it has implemented a Drug Free Work Place program shall be given preference in the award process. In the event both Bidders have a Drug Free Work Place, preference shall be awarded in the following order: Local Vendors as specified in School Board Policy 6450, SBE certified as specified in School Board Policy 6325. If both Bidders meet all requirements, according to standard purchasing practice, the Director of Purchasing will flip a coin to break the tie. Bidder's company name closest to the letter "A" will always be assigned heads in the coin toss.

23. DISPUTE: In case of any doubt or difference of opinion as to the items to be furnished hereunder, the decision of the School Board shall be final and binding on both parties. In the event a dispute occurs, or a clarification of contract terms becomes necessary, please indicate your company representative for arbitration proceedings.

Representative's Name: _____

Telephone Number: _____

Our School Board Representative will be:

*Mrs. Opal McKinney-Williams
Pittman Law Group
(850) 224-9115*

24. PROTESTING BID SPECIFICATIONS: Any person desiring to protest the conditions/specifications in this RFP or any Addenda thereto, shall file a written notice of protest within 72 hours after receipt of the RFP or Addendum and shall file a formal written protest within ten days after the date the notice of protest was filed. Saturdays, Sundays and legal holidays or days during which the School Board administration is closed shall be excluded in the computation of the 72 hour period. If the tenth calendar day falls on a Saturday, Sunday or legal holiday, the formal written protest must be received on or before 4:30 p.m. of the next calendar day that is not a Saturday, Sunday, legal holiday, or day during which the School Board administration is closed.

Failure to file a protest within the time prescribed in section 120.57 (3), Florida Statutes, or failure to post the bond or other security required by law within the time allowed for filing a bond shall constitute a waiver of proceedings under chapter 120, Florida Statutes and School Board Policy 6320.02. Failure to follow any other requirements in the bid protest procedures established by the School Board of Leon County, Florida shall constitute a waiver of all protest rights.

25. PROTESTS TO CONTRACT AWARD: The School Board shall provide notice of a decision or intended decision concerning a solicitation, contract award, or exceptional purchase by electronic posting which can be accessed at the Purchasing Department's website at www.leonschools.net/Domain/195. Any person desiring to protest the intended decision shall file a written notice of protest, within 72 hours after the official posting in the Purchasing Department office of the Notice of Intent to Award concerning this RFP, and shall file a formal written protest within ten days after filing the notice of protest. Saturdays, Sundays, legal holidays and days during which the School Board administration is closed shall be excluded in the computation of the 72-hour period. If the tenth calendar day falls on a Saturday, Sunday

or legal holiday, the formal written protest must be received on or before 4:30 p.m. of the next calendar day that is not a Saturday, Sunday, legal holiday or day during which the School Board administration is closed. Section 120.57(3) (b), Florida Statutes, states that "the formal written protest shall state with particularity the facts and law upon which the protest is based." Any person who files an action protesting an intended award shall post with the Purchasing Department, at the time of filing the formal written protest, a bond payable to the Leon County School Board consistent with F.A.C. Rule 28-110.005(2), and School Board Policy 6320.02. The bond shall be conditioned upon the payment of all costs which may be adjudged against protester in an Administrative hearing in which the action is brought and any subsequent appellate court proceeding. **For the purpose of calculating a protest bond, this contract is valued at approximately \$100,000 annually.** This is only an estimate and actual volume could vary up or down. Failure to file a notice of protest within the time prescribed by Section 120.57(3), Florida Statutes, shall constitute a waiver of proceedings under Chapter 120, Florida Statutes and School Board Policy 6320.02.

26. GOVERNING LAW AND VENUE: All legal proceedings brought in connection with this contract shall only be brought in a state or federal court located in the state of Florida. Venue in state court shall be in Leon County, Florida. Venue in federal court shall be in the United States District Court, Northern District of Florida, Tallahassee division. Each party hereby agrees to submit to the personal jurisdiction of these courts for any lawsuits filed there against such party arising under or in connection with this contract. In the event that a legal proceeding is brought for the enforcement of any term of the contract, or any right arising there from, the parties expressly waive their respective rights to have such action tried by jury trial and hereby consent to the use of non-jury trial for the adjudication of such suit. All questions concerning the validity, operation, interpretation, construction and enforcement of any terms, covenants or conditions of this contract shall in all respects be governed by and determined in accordance with the laws of the State of Florida without giving effect to the choice of law principles thereof and unless otherwise preempted by federal law.

27. COMPLIANCE WITH STATE/FEDERAL REGULATIONS: All contracts involving federal funds will contain certain provisions required by applicable sections of CFR 34, Section 80.36(l) and Part 85.510, Florida Statute 257.36, or Florida Administrative Code Chapter 1B. The bidder certifies by signing the RFP that the bidder and his/her principals are not presently debarred, suspended, proposed for debarment, declared ineligible or voluntarily excluded from participation in federally funded transactions and may, in certain instances, be required to provide a separate written certification to this effect.

During the term of any contract with the School Board, in the event of debarment, suspension, proposed debarment, declared ineligible or voluntarily excluded from participation in federally funded transactions, the Bidder shall immediately notify the Director of Purchasing, in writing. Bidders will also be required to provide access to records, which are directly pertinent to the contract and retain all required records for three (3) years after the School Board makes final payment.

For all contracts involving Federal funds in excess of \$10,000, the School Board reserves the right to terminate the contract for cause, as well as for convenience, by issuing a certified notice to the Bidder.

28. COMPLIANCE WITH SCHOOL CODE: Bidder agrees to comply with all sections of the Florida K-20 Education Code, Title XLVIII, Florida Statutes as it presently exists and further as it may be amended from time to time. Further, Contractor agrees that failure to comply with the Florida K-20 Education Code shall constitute a material breach of this Contract and may result in the termination of this Contract by the School Board.

29. NONDISCRIMINATION NOTIFICATION AND CONTACT INFORMATION: No person shall on the basis of gender, marital status, sexual orientation, race, religion, national origin, age, color, pregnancy or

disability be denied employment, receipt of services, access to or participation in school activities or programs if qualified to receive such services, or otherwise be discriminated against or placed in a hostile environment in any educational program or activity including those receiving federal financial assistance, except as provided by law." No person shall deny equal access or a fair opportunity to meet to, or discriminate against, any group officially affiliated with the Boy Scouts of America, or any other youth group listed in Title 36 of the United States Code as a patriotic society.

An employee, student, parent or applicant alleging discrimination with respect to employment, or any educational program or activity may contact:

Dr. Kathleen L. Rodgers
Equity Coordinator and Title IX Compliance Officer
Leon County School District
2757 West Pensacola Street
Tallahassee, Florida 32304
(850) 487-7306 / rodgersk@leonschools.net

A student or parent alleging discrimination as it relates to Section 504 of the Rehabilitation Act may contact:

Dr. Alan Cox, 504 Specialist
Leon County School District
2757 W. Pensacola Street, Tallahassee, FL 32304
(850) 487-7190 / cox@leonschools.net

30. SBDO PROGRAM: The School Board established the Small Business Development Office to support innovative race and gender neutral strategies to promote qualified small business participation as specified in School Board Policy 6325.

31. LOCAL PREFERENCE: This RFP is subject to the local preference provisions as specified in School Board Policy 6450.

32. FLORIDA PREFERENCE: This RFP is subject to §287.084 Florida Statutes, which requires, among other things, the following: "A vendor whose principal place of business is outside this state must accompany any written bid, proposal, or reply documents with a written opinion of an attorney at law licensed to practice law in that foreign state, as to the preferences, if any or none, granted by the law of that state to its own business entities whose principal places of business are in that foreign state in the letting of any or all public contracts." Any bidder, regardless of whether its principal place of business is located inside or outside of this state, who submits any written bid, proposal or reply documents is responsible for understanding and complying with the requirements of §287.084 Florida Statutes.

33. CHARTER SCHOOLS: Items or services awarded under this contract shall be made available to Charter Schools approved by the School Board. The School Board is not responsible or liable for purchases that may be made by Charter Schools.

II. LICENSURE, INSURANCE AND LIABILITY

1. OCCUPATIONAL LICENSE: The contractor shall be responsible for obtaining and maintaining throughout the contract period any required occupational license and other licenses required pursuant to the laws of Leon County, the City of Tallahassee, or the State of Florida.

2. WORKER'S COMPENSATION: Bidders shall obtain and maintain during the life of the contract Workers' Compensation Insurance in compliance with Chapter 440, Florida Statutes for all of his employees employed on the project. In case any work is sublet, bidder shall require subcontractors similarly to provide Workers' Compensation Insurance.

3. LIABILITY: Where bidders are required to enter or go onto School Board property to deliver materials, perform work or provide services as a result of a RFP award, the bidder assumes full duty, obligation and

expense of obtaining all necessary licenses, permits and insurance, and shall be fully responsible for its own negligent or willful acts or omissions.

4. INSURANCE AND INDEMNIFICATION: This General Condition is NOT subject to negotiation and any Bidder submitting a proposal that fails to accept these conditions will be rejected as "non-responsive", unless bidder is entitled to sovereign immunity by action of the Florida Legislature. Each party agrees to be fully responsible for its acts of negligence, or its agents' acts of negligence when acting within the scope of their employment and agrees to be liable for any damages resulting from said negligence to the extent allowable pursuant to Section 768.28, Florida Statutes. Nothing herein is intended to serve as a waiver of sovereign immunity by the School Board. Nothing herein shall be construed as consent by the School Board to be sued by third parties in any matter arising out of any contract. Bidder shall hold harmless and defend the School Board and its agents and employees from all suits and actions, including attorney's fees and all costs of litigation and judgments of any name and description arising out of or incidental to the performance of this contract or work performed there under. This provision shall also pertain to any claims brought against the School Board by an employee of the named Bidder, any Subcontractor, or anyone directly or indirectly employed by any of them. The bidder's obligation under this provision shall not be limited in any way by the agreed upon contract price as shown in this Contract or the bidder's limit of, or lack of, sufficient insurance protection.

5. RISK OF LOSS: The bidder assumes the following risks: (1.) all risks of loss or damage to all goods, work in process, materials and equipment until the delivery thereof as herein provided; (2.) all risks of loss or damage to third persons and their property until delivery of all goods as herein provided; (3.) all risks of loss or damage to any property received by the bidder or held by the bidder or its suppliers for the account of the School Board, until such property has been delivered to the School Board; (4) all risks of loss or damage to any of the goods or part thereof rejected by the School Board, from the time of shipment thereof to bidder until redelivery thereof to the School Board.

7. PUBLIC ENTITY CRIMES: Pursuant to Florida Statute 287.133 a Bidder, person, or affiliate who has been placed on the convicted Vendors list following a conviction for a public entity crime may not submit a RFP on a contract to provide any goods or services to a public entity for the construction or repair of a public building or public work, may not submit RFPs on leases of real property to a public entity, may not be awarded or perform work as a contractor, supplier, subcontractor, or consultant under a contract with any public entity, and may not transact business with any public entity in excess of the threshold amount provided in Florida State Statute, Section 287.017, for CATEGORY TWO for a period of 36 months from the date of being placed on the convicted vendor list.

8. PATENTS AND COPYRIGHTS: Bidders agree to indemnify and save harmless the School Board, its officers, employees, agents, or representatives using the goods specified herein from any loss, damage or injury arising out of a claim or suit at law or equity for actual or alleged infringement of letters of patent by reason of the buying, selling or using the goods supplied under this RFP, and will assume the defense of any and all suits and will pay all costs and expenses thereto.

9. PUBLIC RECORDS LAW: PUBLIC RECORDS LAW: Pursuant to Florida Statutes Chapter 119.071(1), proposals received as a result of this RFP will not become public record until thirty (30) days after the date of opening or until posting of a recommendation for award, whichever occurs first.

Thereafter, all proposal documents or other materials submitted by all bidders in response to this RFP will be open for inspection by any person and in accordance with Chapter 119, Florida Statutes. To the extent a Bidder asserts any portion of its proposal is exempt or confidential from disclosure under Florida's public records, the burden shall be on the bidder to obtain a protective order from a jurisdictional court protecting

such information from disclosure under Florida's public records laws and also timely provide a certified copy of such protective order to the School Board prior to the School Board's release of such information into the public domain.

AUDITS, RECORDS, AND RECORDS RETENTION: To the extent Contractor is required to comply with the Florida Public Records Law, Chapter 119, Florida Statutes, in the performance of its duties under this contract, Contractor will specifically:

- A. Keep and maintain public records required by LCSB to perform the service.
- B. Upon request from LCSB's custodian of public records, provide LCSB with a copy of the requested records or allow the records to be inspected or copied within a reasonable time at a cost that does not exceed the cost provided in the Chapter 119, Florida Statutes or as otherwise provided by law.
- C. Ensure that public records that are exempt or confidential and exempt from public records disclosure requirements are not disclosed except as authorized by law for the duration of the contract term and following completion of the Agreement if Contractor does not transfer the records to LCSB.
- D. Upon completion of the Agreement, transfer, at no cost to LCSB, all public records in possession of the Contractor or keep and maintain public records required by LCSB to perform the service. If Contractor transfers all public records to LCSB upon completion of the Agreement, Contractor shall destroy any duplicate public records that are exempt or confidential and exempt from public records disclosure requirements. If Contractor keeps and maintains public records upon completion of the Agreement, Contractor shall meet all applicable requirements for retaining public records. All records stored electronically must be provided to LCSB, upon request of LCSB's custodian of public records, in a format that is compatible with the information technology systems of LCSB.
- E. The failure of the Contractor to comply with the provisions set forth herein shall constitute a default and material breach of this Agreement, which may result in immediate termination, with no penalty to LCSB.

PUBLIC RECORDS NOTICE

IF CONTRACTOR HAS QUESTIONS REGARDING THE APPLICATION OF CHAPTER 119, FLORIDA STATUTES, TO CONTRACTOR'S DUTY TO PROVIDE PUBLIC RECORDS RELATING TO THIS AGREEMENT, CONTACT THE CUSTODIAN OF PUBLIC RECORDS, JULIE JERNIGAN, AT JERNIGANJ@LEONSCHOOLS.NET, (850)487-7363, 520 SOUTH APPELYARD DRIVE, TALLAHASSEE, FLORIDA 32304.

III. GOODS AND SERVICES

- 1. WARRANTY:** All goods and services furnished by the bidder, relating to and pursuant to this RFP will be warranted to meet or exceed the Specifications contained herein. In the event of breach, the bidder will take all necessary action, at bidder's expense, to correct such breach in the most expeditious manner possible.
- 2. PRICING:** All pricing submitted will include all packaging, handling, shipping charges and delivery to any point within Leon County, Florida to a secure area or inside delivery. ***The School Board is exempt and does not pay Federal Excise and State of Florida sales taxes.***
- 3. PRICE ESCALATION:** In the event of unforeseen circumstances that directly impact the pricing and/or servicing of this contract, the School RFP 473-2022 Fencing Materials and Installation District Wide

Board reserves the right to negotiate the established prices with the contractor at any time during the duration of this contract after completion of the initial contract term. Price negotiations will be at the sole discretion of the School Board.

The School Board may consider pricing increases of the item(s) if the following conditions occur:

- A. There is a verifiable price increase of the bid item(s) to the contract supplier.
- B. The contractor submits to the School Board, in writing, notification of price increases.
- C. The price increase shall be comparable to documented manufacturers' or distributors' price changes or changes in industry related indices.
- D. The contractor shall submit the above information to the Director of Purchasing thirty (30) calendar days prior to the effective date of the price increase. Requests for price increases may only be made after the first term of the contract.

When the contractor complies with the abovementioned conditions, the Director of Purchasing will review the information to determine if it is in the best interest of the School Board to adjust the pricing on the products proposal, in conjunction with the contractor's effective date of price increase. The School Board reserves the right to deny any requests for price increases. The contractor must receive written notification from the Director of Purchasing that the School Board is in acceptance of the new prices before processing any orders with the new costs.

4. QUANTITIES: Quantities listed in the RFP are estimates provided for bidder information purposes only. No guarantee is given or implied as to the exact quantities, which will be purchased from this RFP. The School Board reserves the right to increase or decrease all estimated quantities during the term of this contract or to delete any item or items as it deems appropriate, without affecting the pricing or the terms and conditions of the RFP.

5. MOST FAVORED CUSTOMER STATUS: The awarded bidder shall afford the School Board the most favored customer status for all items herein. Accordingly, if during the term of this contract, the contractor offers more favorable promotional or contract pricing to another entity for the same specification with similar quantities and conditions, the price under this contract shall be immediately reduced to the lower price. Additionally, if a current state of Florida contract, or other viable piggy-back contract contains more favorable pricing for the same specification with similar quantities and conditions, the contractor will be afforded an opportunity to adjust its contract price to match that of the state of Florida contract. Should the contractor decline, LCSB reserves the right to purchase the item(s) from the state of Florida or alternate piggy-back contract.

6. TERMS OF PAYMENT / INVOICING: The normal terms of payment will be Net 30 Days from receipt and acceptance of goods or services and contractor's invoice. Itemized invoices, each bearing the Purchase Order Number must be mailed on the day of shipment. Invoicing subject to cash discounts will be mailed on the day that they are dated.

7. PURCHASING CARDS: The School Board may choose to use a "Purchasing Card" for ordering of goods and materials or payment of invoices under this contract. The bidder, by submitting a proposal, agrees to accept this manner of payment and may not add additional handling charges or service fees to purchases made with the School Board's Purchasing Card(s). Refusal to accept this condition may cause the proposal to be declared non-responsive, or result in revocation of the contract, if already awarded. No third party payment, i.e. Pay pal will be considered

8. TRANSPORTATION AND TITLE: (1) Title to the goods will pass to the School Board upon receipt and acceptance at the destination indicated herein. Until acceptance, the Bidder retains the sole insurable interest in

the goods. (2) The shipper will prepay all transportation charges. The School Board will not accept collect freight charges. (3) No premium carriers will be used for the School Board's account without prior written consent of the Director of Purchasing.

IV. BIDDER REQUIREMENTS

1. E-VERIFY: Every Contractor must register with and use the U.S. Department of Homeland Security's E-Verify system to verify the work authorization status of all employees hired during the term of this Agreement and must, upon request, provide evidence of compliance with this provision. Subcontractors shall provide Contractor with an affidavit stating the Subcontractor does not employ, contract with, or subcontract with an unauthorized alien. See Section 448.095, Florida Statutes, for all requirements

2. REFERENCES: Each Bidder is required to submit a list of three (3) customer references using the format on the attached "Customer Reference Form" see Exhibit D. The Bidder must be the prime contractor for each customer/contract referenced. All references shall be for work performed over the last year at commercial, multi-residential developments and/or institutional complexes for contracts of comparable size. Newly formed companies, corporations, joint ventures; etc. may use an incorporator as a referenced entity. At least one contract/customer shall have been serviced for a minimum of one year. Failure to provide verifiable references may result in the bidder not being considered for award. Unsatisfactory references may result in the bidder not being considered for award.

2. LEVEL 2 SCREENING REQUIREMENTS: The following provisions, which implement the requirements of School Board Policy 8475, Florida Statute Sections 1012.315, 1012.32, 1012.465 (Jessica Lunsford Act), 1012.467 and 1012.468 are included as additional terms and conditions of the contract.

Finger Printing and Background Check:

The bidder/contractor agrees to comply with all requirements of School Board Policy 8475 and Florida Statute Sections 1012.315, 1012.32, 1012.465 (Jessica Lunsford Act), 1012.467 and 1012.468 by certifying that any/all employees have completed the mandatory background screenings as required by the referenced policy and statutes and shall provide the School Board with proof of compliance. These certifications will be provided to the Leon County School Board, Safety & Security Department in advance of the Bidder/contractor providing any/all services as required herein. The Bidder/contractor will bear the cost of acquiring the background screening required and any/all fees imposed by the Florida Department of Law Enforcement and or the School Board to maintain the fingerprints provided with respect to Bidder/contractor and its employees. Contractor agrees to indemnify and hold harmless the School Board, its officers, agents and employees from any liability in the form of physical injury, death, or property damage resulting from the Contractor's failure to comply with the requirements of these cited policies and statutes. The Bidder/contractor will follow procedures for obtaining employees background screening as established by the Leon County School Board, Safety & Security Department.

Where: Leon County School Board – Safety & Security Department
2757 W. Pensacola St.
Tallahassee, Florida 32304

When: Monday-Friday
8:00 a.m. – 5:00 p.m.

Point of Contact: Donald Kimbler @ 850-487-7293

LCSB Policy 8475 is subject to review and change. As a provision of this contract, if awarded, any changes made to this policy will automatically become a part of and be incorporated in this contract. It is the responsibility of the awardee(s) to be aware of any changes that may occur.

3. RECIPROCITY OF FLORIDA SCHOOL I.D. BADGES: If contractor has a Level II clearance registered with another Florida School Board, they may be able to obtain a Leon County School Board vendor I.D. badge. Contractor should check with the Safety & Security Department Fingerprint Services office to verify clearance and obtain a vendor I.D. badge.

4. IDENTIFICATION: All personnel employed by the bidder, including any subcontractor and subcontractor's employees when applicable, shall display at all times an identification badge which shall include the employee's name, the employer's name and either a physical description or a photograph of the employee. Employees without proper identification shall not be permitted to work under the terms of this Agreement.

5. CONTACT WITH STUDENTS: No employees or independent contractors, material men, suppliers or anyone involved in any manner with projects resulting from this proposal shall have direct or indirect contact with students at project sites. A violation of this provision shall result in immediate termination of the offender and issuance of a trespass notice from the School Board. Bidder/Proposer shall be responsible for insuring compliance by all employees, independent contractors and sub-contractors or other persons involved in any manner with projects resulting from this proposal.

6. WEAPONS AND FIREARMS: The School Board prohibits any contractor from possessing, storing, making, or using a weapon, including a concealed weapon, on School Board property and any setting that is under the control and supervision of the School Board as specified in School Board Policy 7217. Violations will be subject to the immediate termination of the contract.

7. SMOKING AND TOBACCO PRODUCTS: Smoking and the use of tobacco products are prohibited on school property, including all buildings and grounds. A warning will be assessed for the first offense and termination of the Agreement may be imposed for any second or additional offense.

8. ATTIRE: Proper attire shall be worn at all times.

- A. Shirts shall be worn awhile on school property at all times. (No tank tops or undershirts will be permitted).
- B. Clothing displaying nudity, obscene language, obscene symbols or pro-drug slogans is prohibited.
- C. Proper shoes to insure the individual's safety shall be worn at all times.

9. INSPECTIONS AND TESTING: The School Board will have the right to inspect and test any of the goods or services covered by this RFP. All goods or services are subject to the School Board's inspection and approval upon arrival or completion. If rejected, goods will be held for disposal at the bidder's risk. Such inspection, or the waiver thereof, however, will not relieve the bidder from full responsibility for furnishing goods or services conforming to the requirements of this RFP or the RFP Specifications, and will not prejudice any claim, right, or privilege the School Board may have because of the use of defective or unsatisfactory goods or service. All deficiencies noted by the School Board will be submitted to the contractor for correction within ten (10) calendar days after submission of deficiencies to the contractor. An additional inspection of the goods or service may be conducted to insure corrective action was taken.

10. STOP WORK ORDER: The School Board may at any time, by written notice to the Bidder stop all or any part of the work for this contract award. Upon receiving such notice, the bidder will take all reasonable steps to minimize additional costs during the period of work stoppage. The School Board may subsequently either cancel the stop work order resulting in an equitable adjustment in the delivery schedule and/or the price, or terminate the work in accordance with the provisions of the RFP terms and conditions.

- A. Materials or work are not in conformance with applicable codes, standards, School Board specifications and/or accepted practices.
- B. The contractor's activities result in damage to School board property.
- C. The contractor's activities interfere with the normal operation of the facility.
- D. Contractor's personnel are not properly licensed to perform the work or as it pertains to school facilities, the contractor's personnel have not received their Level II background clearances.
- E. Any other condition, situation, or circumstance, which in the opinion of the School Board Authorized Representative would be a detriment to the best interests of the School Board if allowed to persist.

11. SAFETY: The bidder shall be responsible for instructing their employees in all safety measures. All equipment used by the bidder shall be free from defects or wear that may in any way constitute a hazard to any person or persons on School Board property. At no time shall equipment be operated without guards, shields, or other manufactures recommended safety accessories in place and functioning as intended by the manufacturer. All current OSHA safety standards shall be reinforced including, but not limited to, the following rules:

- A. All OSHA and Federal required safety equipment shall be installed and functioning on all equipment.
- B. All equipment shall be in sound working condition and must meet all OSHA Safety Standards. All workers shall be aware of and trained in the operation of all safety equipment required for this project.
- C. The Bidder shall ensure that employees are equipped with proper safety items such as glasses, hard hats, gloves, etc.
- D. All incidents on campus involving School Board property or personnel shall be reported to the Director of Maintenance Services Department and the Campus Administrator immediately upon occurrence.
- E. All debris shall be removed to an environmentally approved landfill or recycling center.

12. EMERGENCIES: In any emergency affecting the safety of persons and property, the awarded contractor shall act immediately to prevent threatened damage, injury or loss. Any emergency must be reported to an authorized School Board representative immediately and no later than twenty-four (24) hours from the time that the emergency is discovered by the contractor

13. DAMAGE TO SCHOOL BOARD OWNED PROPERTY: Any damage to property, equipment, grounds, buildings, etc. that is caused by the awarded contractor will be reported to the School Board within twenty-four (24) hours of discovery. The awarded contractor will have ten (10) working days after report to present its written response to the claimed damages. The awarded contractor, upon approval by an authorized School Board representative, may make repairs that are deemed within its capability. The School Board reserves the right to make immediate repairs to correct damages that are safety hazards or that pose a detrimental effect to the School Board's operations. Costs of any replacement or repairs made by the School Board for damages caused by the awarded contractor shall be deducted from any monies due to the contractor. This shall not prevent the School Board from seeking damages should replacement/repair costs exceed the amount of monies owed to the awarded contractor. When requested, Bidder shall cooperate with any ongoing School Board investigation involving personal injury, economic loss or damage to The School Board's facilities or personal property therein.

14. SUBCONTRACTING: The awarded contractor(s) shall be the primary service provider(s) and shall perform all requested inspections and repairs. Subcontracting for these base services is not allowed.

- A. The School Board, for work where the contractor(s) are requested to perform additional services, may allow subcontracting.
- B. Any work or service to be performed by a subcontractor must have the prior approval of the School Board. The School Board reserves the right to reject any subcontractor. Rejection of any subcontractor shall not entitle the contractor to adjustment of RFP prices. The contractor shall inform the School Board Authorized Representative prior to scheduling any subcontractor's visit to any School Board facility.
- C. Failure by the contractor to have a subcontractor approved by the School Board will not relieve the contractor of the responsibility to meet, comply with, and fulfill all of the terms and conditions of this Agreement.
- D. The contractor(s) shall be held fully responsible and liable for the supervision and performance of all work performed by subcontractors. The School Board shall not be responsible for resolution of disputes between the Bidder and any subcontractor.
- E. The personnel of all subcontractors shall meet all of the requirements as stated herein to include, but not limited to LCSB Policy 2.021 and the Jessica Lunsford Act.

15. ON-CAMPUS DIRECTIVES

- A. Upon arrival and departure onto any School Board school campus, the contractor's employees shall enter their company information into the School Log Book provided in the Administrative office of each campus.
- B. Contractor shall strictly limit its operations to the designated work areas and shall not permit any employees to enter any other portions of School Board property without School Board's expressed prior written consent.
- C. All employees shall enter and leave School Board facilities only through the ingress and egress points designated, from time to time, by The School Board.
- D. The contractor shall be responsible for the removal of all trash and debris occasioned by this contract. Failure to adhere to this requirement will result in the costs of the performance of this work by others being charged to the contractor.
- E. Any existing surface or subsurface improvements, including, but not limited to, pavements, curbs, sidewalks, pipes, utilities, footings, structures, trees and shrubbery, not indicated in the contract documents to be removed or altered, shall be protected by contractor from damage during the prosecution of any project. Any such improvements so damaged shall be restored by contractor to condition at least equal to that existing at the time of contractor's commencement of any project.
- F. Proper safety barricades, protective, and covering devices shall be used to divert traffic and protect personnel. Normal safety signs, necessary lighting and temporary fencing/barricades around work areas shall be installed and maintained in accordance with OSHA requirements while the work is in progress. Materials must be secured in accordance with OSHA regulations when not in use.

16. BIDDER ACCESSIBILITY: The successful bidder shall provide a liable and responsible representative to be accessible by a Leon County toll free local telephone call during regular business hours. Local off-hours answering service for emergencies shall be available for bidder notification twenty-four (24) hours a day, seven (7) days per week, all year, including holidays.

17. CONTACT PERSON: The successful Bidder shall be notified of the name and phone number of the School Board contact person. Only the School Board contact person may authorize changes to the scope of work.

V. SCOPE OF WORK AND SPECIFICATIONS

- A. INTENT:** It is the intent of the School Board to establish a firm, fixed price contract with qualified fencing contractors to provide materials and labor for the installation of security, chain link, PVC Coated, and ornamental fencing and to perform repairs, maintenance and other minor fencing projects on an as needed basis district wide as specified herein for the period August 25, 2021 – June 30, 2023. The School Board reserves the right to renew the contract awards for three (3) additional one (1) year periods upon mutual agreement in writing. Firm fixed prices shall include all labor, materials (when necessary), equipment and supervision to perform fencing installation, repair and maintenance services.
- B. CONTRACTOR QUALIFICATIONS:** These qualifications will serve as the minimum requirements for Contractors submitting proposals in response to this RFP.

 - 1. At the time of submitting their proposal, and throughout the term of this Agreement, Contractors shall possess all active permits, licenses, and certifications required to operate a commercial fencing business.
 - 2. The Contractor submitting their proposal shall have been in business for a **minimum of three (3) years** as a fencing contractor, doing installation, maintenance and repairs for commercial, industrial, institutional and/or school districts of like size, and shall present documentation verifying that experience.
 - 3. **The Contractor shall maintain offices, shop facilities and personnel located in the counties of Leon, Gadsden, Liberty, Wakulla or Jefferson County, Florida.** The Contractor shall be accessible, toll free by telephone from Leon County during regular business hours. The Contractor shall submit a list of the names and all cellular phone numbers of their service managers, service supervisors, service salesmen, service technicians and service dispatchers. An answering service for emergencies capable of contacting Contractor’s appropriate staff shall be available on a twenty-four (24) hour basis during the term of this Agreement.
 - 4. The Contractor shall supply a list of all service personnel who will be performing service to the Board during the term of this Agreement. The list should include the following information:

 - a. years of fencing service experience
 - b. list of qualifications
 - c. copies of resume’s and all supporting certifications
 - 5. **All required Contractor qualification documents shall be submitted with the proposal.** All qualification documents shall be evaluated by the District before any recommendation of award will be made. During the term of this Agreement, any change in the license status of the Contractor, Contractor’s subcontractor(s) if allowed, or technicians’ certificate status, shall be reported, in writing, to the District Authorized Representative within five (5) working days of the occurrence.
 - 6. The Contractor is required and shall have the staffing capability to simultaneously perform work at multiple locations throughout the District when requested to do so.
 - 7. It is the responsibility of the Contractor to comply with all codes and regulations as they pertain to performance of the work under the terms of this Agreement.
- C. ADMINISTRATIVE PROCEDURES FOR PROJECTS ESTIMATED NOT TO EXCEED \$50,000:** The awarded contractor(s) will provide, as requested, job estimates at no charge to the District. At the School Boards discretion, competing quotes may be solicited for projects not estimated to exceed Fifty Thousand Dollars (\$50,000.00). The firm prices as proposed under this agreement will be the basis for all services/billings as a result of performance of award under this contract.

 - 1. Contractor shall be notified of the project and site location.
 - 2. When necessary, a mutually agreed upon date and time shall be arranged between the Contractor and School Board project coordinator responsible for overseeing the project.
 - 3. After a general overview of the project is given to the Contractor on site or verbally, Contractor shall prepare a written proposal using the Work Order Form as shown in Exhibit J to include but not limited to:

 - a. a brief description of work to be completed
 - b. number of labor hours estimated to complete the project

- c. material and/or equipment cost estimate if applicable
 - 4. Upon acceptance of the job estimate the contractor will be requested to perform the project specific duties as assigned. The timeframe of each project will be “as required” and at the direction of the District appointed project coordinator. The project will be deemed complete when the work has been reviewed and approved by the project coordinator or his designee. Once completed, the contractor should submit to the project coordinator or his designee, an itemized invoice showing date, location, hourly labor rates for all position titles and materials (cost and mark-up) necessary for each individual project assigned.
- D. **ADMINISTRATIVE PROCEDURES FOR PROJECTS ESTIMATED COST > \$50,000 AND < \$100,000:** It is the intention of the School Board to contract with the lowest most responsive qualified licensed Contractor meeting specifications for projects anticipated to exceed Fifty Thousand Dollars (\$50,000.00), the formal Bid threshold as established in Board Policy 6320, but less than One Hundred Thousand Dollars (\$100,000.00). To that end, for individual projects estimated to exceed Fifty Thousand Dollars (\$50,000.00) competing quotes will be solicited. The firm prices as proposed under this agreement will be the basis for all services/billings as a result of performance of award under this contract.
- 1. Contractor shall be notified of the project and site location.
 - 2. When necessary, a mutually agreed upon date and time shall be arranged between the Contractor and School Board project coordinator responsible for overseeing the project.
 - 3. After a general overview of the project is given to the Contractor on site or verbally, Contractor shall prepare a written sealed quote to include:
 - a. a brief description of work to be completed.
 - b. number of labor hours estimated to complete the project.
 - c. material and/or equipment cost estimate if applicable.
 - 4. Upon acceptance of the job estimate the contractor will be requested to perform the project specific duties as assigned. The timeframe of each project will be “as required” and at the direction of the District appointed project coordinator. The project will be deemed complete when the work has been reviewed and approved by the project coordinator or his designee. Once completed, the contractor should submit to the project coordinator or his designee, an itemized invoice showing date, location, hourly labor rates for all position titles and materials (cost and mark-up) necessary for each individual project assigned.
 - 5. Final costs for any individual project shall not exceed the original approved and firm estimate/total cost for such project by more than ten percent (10%) and/or the amount of the purchase order. Any and all anticipated project cost increases must be approved in advance by the Director of Purchasing and shown as a “change order” on the existing purchase order.
 - 6. If the Contractor does not wish to issue a quote for or cannot meet the requirements of the project, inclusive of the time given in which to complete the job; the Contractor shall respond in writing with a “No Quote” and provide an explanation as to why they are not submitting a quote. ***Any Contractor that fails to submit a request for quote successively three (3) times in a row may have their contract cancelled due to non-performance.***
- E. **REASSIGNMENT OF WORK:** The Board reserves the right and authority to reassign work to another Contractor, at any time, for the following reasons:
- 1. The assigned and/or lowest cost Contractor cannot comply with the specifications in cases of an emergency.
 - 2. The assigned and/or lowest cost Contractor cannot respond to the job requirements, at the time, due to scheduling conflicts, staffing considerations or other reasonable cause(s) for preventing their completion of the project as required.
 - 3. The Board shall have the option to solicit additional quotes, bids, or even professional opinion about a particular project and could engage the services of another fencing company/contractor when in its best interest.

- F. **REMUNERATION:** Contractor shall be paid a fee based on the unit price submitted on the Cost Proposal Form of this RFP as follows:
1. For all hours worked per each labor classification and whether the work was performed during regular or overtime hourly rate basis; ***The hourly labor rates, whether at a regular or overtime rate basis; shall be inclusive of all associated costs with the performance of these services including transportation, equipment, delivery, miscellaneous expenses, profit and overhead.***
 2. The cost for all purchased materials and supplies required to complete the job (if any), plus the applicable and approved percentage markup rate over cost for materials not on the cost proposal form; copies of all related invoices for materials and supplies not on the cost proposal form shall be provided as backup to all invoices submitted for payment by the Board to the Contractor. The calculation for the percentage markup shall be clearly indicated as well.
- G. **PERMITTING:** Leon County Schools will assume responsibility for any and all fees associated with permitting. Any Fence 7' or greater in height requires permitting through LCS Code Enforcement at <https://www.leonschools.net/Domain/6096>
- H. **MATERIALS ACQUISITION:** The District is requesting a percentage (%) materials mark-up price from each bidder as part of this RFP. **The District will NOT accept any materials markup pricing that is in excess of 25% of the awarded contractors actual cost for the materials. The mark up percentage may not be applied to any amount the Contractor pays in sales tax for the materials or equipment.** The awarded contractor, upon request, must provide, the original invoice showing the contractors actual cost for any materials as provided. **Further, the District reserves the right to acquire by its own means any equipment or materials necessary to perform the scope of work as delineated in this contract.**
- I. **SCOPE OF WORK GENERAL:**
1. The contractor shall furnish at their expense all supervision, equipment, tools, machinery, labor, materials, transportation and other items and services necessary to fully accomplish the projects as assigned in accordance with the terms, conditions and specifications of this RFP.
 2. All work shall be accomplished in strict accordance with specifications set forth herein, and all applicable state, county and local laws, codes and ordinances. In addition, without exception, the contractor shall comply with the letter and intent of all EPA, OSHA, and any other pertinent federal regulations and laws concerning the work specified herein.
 3. The contractor is responsible for the protection of all buildings, structures and utilities that are under or above ground or on the surface, from their operations that may be hazardous and/or damaging to said facilities.
 4. The contractor is responsible for the protection of all students, visitors, and District personnel against hazards and/or injuries due to their operations at the work site.
 5. The contractor shall not block exits, hallways, corridors, driveways, delivery areas, nor impede ingress or egress.
 6. The contractor shall not impede nor interfere with the normal function of the facility, its occupants or programs.
 7. The contractor shall ensure frequent pick-up of all refuse, rubbish, scrap materials and debris that result from their operations so that the work site presents a neat and orderly appearance at all times. All rubbish, scrap, etc. shall be transported from the premises. At completion of work the contractor shall remove all work materials, tools, equipment, and surplus materials from the work site and leave project in ready-to-use condition. The District is not responsible for loss of tools or supplies.
- J. **FAMILIARITY WITH SITES:** All Bidders are encouraged to make site inspections of typical schools to familiarize themselves with the unique environment where the work is to take place and to establish work procedures that minimize disruption of the school day. A District representative is available to answer questions regarding problems, safety considerations or other conditions unique to the District. Submission of a bid shall constitute acknowledgement by the Bidder that he is familiar with all site conditions. The failure or neglect of a Bidder to familiarize himself with the site of the proposed work shall in no way relieve him from any obligations with respect to his bid and shall not entitle the awarded contractor to additional compensation after contract award.

- K. **REFERENCES:** Each Bidder is required to submit a list of three (3) references using the format on the attached "Customer Reference Form". Bidder must be the prime contractor for each customer/contract referenced. All references shall be for work performed over the last year at commercial, multi-residential developments and/or institutional complexes for contracts of comparable size. Newly formed companies, corporations, joint ventures; etc. may use an incorporator as a referenced entity. At least one contract/customer shall have been serviced for a minimum of one year. Failure to provide verifiable references will result in the Bidder not being considered for award. Unsatisfactory references may result in the Bidder not being considered for award.
- L. **RESPONSE TIME:** The contractor will be required to respond to any request for routine service within **forty-eight (48) hours'** notice. Routine service is defined by these specifications as regularly scheduled work/maintenance not deemed to be an emergency as requested by the District Authorized Representative.
- M. **EMERGENCY SERVICE:** In the case of a designated emergency, the awarded contractor must be able to respond to an emergency call within two (2) hours. Emergency service is defined by these specifications as an unexpected situation or occurrence that demands two (2) hour response by the contractor due to acts of nature or any situation that effects the safety of persons or property as declared at the sole discretion of the District Authorized Representative
- N. **WORKING DAY:** The normal working hours for the District are between 7:00 a.m. and 5:00 p.m. Monday through Friday. Projects will be mutually scheduled as required by the District's interests. Such scheduling will include off hours, weekends and holidays.
- O. **OVERTIME:** The awarded contractors must be available to provide service after normal working hours. Overtime pay as quoted on the Cost Proposal Form shall be paid for all hours worked after 5:00 p.m. and before 7:00 a.m. on weekdays and any work performed on weekends and holidays
- P. **NON-EXCLUSIVE:** The District reserves the right to perform, or cause to be performed, the services herein described in any matter it sees fit, including, but not limited to, award of other contracts, utilization of existing State or County contracts, or to perform the work with its own employees.
- Q. **LAWS AND CODES:** All work shall be accomplished in strict accordance with specifications as set forth herein, and all applicable federal, state, county and local laws, codes, ordinances and School Board policies. In addition, without exception, the awarded contractor(s) shall comply with the letter and intent of all EPA, OSHA and any other pertinent federal regulations and laws as they apply.
- R. **INSPECTION OF WORK:** The District reserves the right to inspect the contractor's work at any time to assure compliance with all terms and conditions of this Agreement. All work will be inspected pursuant to applicable codes. All deficiencies noted by the District will be submitted to the contractor for correction. Within thirty (30) calendar days after submission of deficiencies to the contractor, an inspection of the system may be conducted to insure corrective action was taken. Should the deficiencies not be corrected, the contractor shall be liable for any cost incurred by the District to insure the correction to include, but not limited to, additional inspections, repairs and meetings.
- S. **IMPLEMENTATION SCHEDULE:** The estimated schedule for selecting and awarding this contract is as follows:

Mailing/Posting of Request for Proposals	July 14, 2021
Submission of Questions by Proposers	July 27, 2021
Posting of Responses to Questions	July 28, 2021
Opening of Proposals	August 10, 2021
<i>(Proposals due no later than 2:00 P.M.)</i>	
Evaluation of Proposals	August 10 – August 13, 2021
Notice of Intent to Award Posted on or about	August 16, 2021
School Board Consideration Date	August 24, 2021
Contract Inception Date after Board Approval	August 25, 2021 <i>(on or about)</i>

T. EVALUATION CRITERIA:

EVALUATION FACTORS WILL INCLUDE, BUT NOT BE LIMITED TO THE FOLLOWING:	MAXIMUM ASSIGNED POINTS
CRITERION 1: Responsiveness of the Proposal <ul style="list-style-type: none"> • The respondent’s ability to comply with the minimum qualifications and mandatory requirements of the RFP 	10
CRITERION 2: Profile and Qualifications of the Firm <ul style="list-style-type: none"> • The ability, capacity, and skill of the Firm to be able to provide the services • Stability and Viability of the Firm 	20
CRITERION 3: Qualifications of Personnel	30
CRITERION 4: Quality of References	10
CRITERION 5: Cost Proposal	30

VI. TECHNICAL SPECIFICATIONS - ALUMINUM SECURITY FENCES AND GATES

PART 1 - GENERAL:

- A. Description** - Furnish an industrial series grade aluminum ornamental fence and accessory materials. The work includes, but is not limited to the fencing, gates and related hardware.
- B. Quality Assurance**
 - 1. Tests
 - a. AAMA 2605 – Covers high performance organic coatings on architectural extrusions and panels.
 - b. ASTM D2247 – Humidity resistance of 3000 hours.
 - c. ASTM B117 – Salt spray resistance of 3000 hours.
 - d. Accelerated weathering for 1000 hours under Method 6152 of Federal Test Method 141 shall show no adhesion loss, with only slight fading, chalking and water staining.
 - e. Outdoor weathering shall show no adhesion loss, checking of crazing, with only slight fade and chalk when exposed for five years in Florida facing south at a 45 degree angle.
 - 2. Emergency Access Requirements: Comply with requirements of local authority having jurisdiction for gates with panic hardware and closers serving a required means of access.
- C. PERFORMANCE REQUIREMENTS**
 - 1. Delegated Design: Design aluminum fences and gates, including comprehensive engineering analysis by a qualified engineer, using performance requirements and design criteria indicated.
 - 2. Structural Performance: Aluminum Fences and Gate framework shall withstand the effects of gravity loads and the following stresses within limits and under conditions indicated according to applicable codes.
- D. SUBMITTALS**
 - 1. Product Data - for each type of product indicated include construction details, material descriptions, dimensions of individual components and profiles and finishes for aluminum fences and gates.
 - 2. Shop Drawings:
 - a. Shop drawings in sufficient detail to show fabrication, anchorage and interface of the work. Include plan layout, accessories, fittings, and hardware (excluding items not in contract).
 - b. Include plans, elevations, sections, details, and attachment to other work. Show accessories, hardware, gate operation, and operational clearances.
 - 3. Samples for verification: Prepared on sample size indicated below
 - 4. Product Certificates: For each type of aluminum fence from manufacturer
 - 5. Product Test Reports: For Framing strength

6. Warranty: Sample of Special Warranty

E. PROJECT CONDITIONS

1. Field Measurement: Verify layout information for aluminum fences and gates shown on drawings in relation to property survey and existing structures. Verify dimensions by field measurements

F. WARRANTY

1. The entire fence system shall have a limited lifetime warranty against defects in workmanship and material while the finish must also carry a limited lifetime warranty against cracking, chipping or peeling.

G. PERMITTING

1. Any fence 7' or greater in height requires permitting through LCS Code Enforcement (<https://www.leonschools.net/Domain/6096>)

PART II – PRODUCTS

A. MANUFACTURERS – BASIS OF DESIGN

1. Barrette Outdoor Living
7830 Freeway Circle
Middleburg Heights, Ohio 44130
www.barrettoutdoorliving.com
2. Or Approved Equal

B. MATERIALS

1. Aluminum Extrusions: The structural members of the fence shall be extruded from HS-35™ aluminum alloy (or an equivalent performing alloy) with minimum yield strength of 35,000 PSI. Pickets shall be extruded Aluminum manufactured from HS-35 (or an equivalent performing alloy) with a minimum yield strength of 25,000 PSI. 6063-T5 aluminum alloy does not meet these performance requirements and is therefore not permitted.
2. Fasteners: All fasteners shall be stainless steel with a zinc dichromate coating for enhanced corrosion resistance. Phillips head screws shall be used to attach the pickets to the rails while self-drilling, self-tapping (Phillips) head screws shall be used to connect the rails to the post. All screws shall be painted to match the finish of the fence.
3. Accessories: All castings used for post caps, finials, scrolls, rail/base attachments and latches shall be made from aluminum. Zinc castings are not allowed. Only stainless steel fasteners may be used with these accessories. All accessories will be painted to match the finish of the fence.

C. FINISH

1. Pretreatment: Before the finish is applied, a five-stage pretreatment must be applied to assure maximum adhesion and corrosion resistance.
 - a. Stage 1: High alkaline cleaner to prepare the surface
 - b. Stage 2: Water rinse
 - c. Stage 3: Conversion coating for maximum adhesion and corrosion
 - d. Stage 4: Water rinse
2. Coating: After the pretreatment, the metal is dried and super-durable powder coating shall be applied. The finish shall meet or exceed all of the AAMA 2605 specifications, including 3,000 hours of salt spray testing under ASTM B117.
3. Color: The color to be selected by the architect from the manufacturer's standard color selections.

D. CONSTRUCTION

1. Industrial Series
 - a. Horizontal Rails shall be 1-5/8" square "U" channels. Pickets shall pass through holes punched in the top rail. The rails shall have a top wall thickness of 0.70" and a side wall thickness of .100". The number of rails shall vary according to manufacturer specifications.

- b. Pickets shall be fastened to the rails using zinc-coated stainless steel screws painted to match the color of the fence. Screws shall be used on only one side of the rail leaving the other side with a clean appearance. Pickets shall be 1" square with a .062" wall thickness. Welding the pickets to the rails will not allow the fence to rake and is unacceptable.
- c. Posts shall be 2-1/2" square with a .075" wall thickness.
- d. Gate posts shall be 4" square with a .125" wall thickness. A gate requires a gate post on both sides. A cast aluminum cap is to be used on all posts.
- e. Spreader Bar shall be 4" square with a .125 wall thickness.
- f. Spacing shall be 3-31/32" between pickets.
- g. Installed centers shall be 71" on center (2-1/2" posts)
- h. Height shall be 48", 60", or 72"
- i. Color shall be black
- j. Horizontal rails shall be 3 on 48", 60", 72"; and 4 on 84", 96" height if applicable
- k. Swing Gates
 - 1. shall be fabricated to manufacturer's standard methods
 - 2. Framework shall be 2 1/2" square with a .125" wall thickness
 - 3. NO Spring hinges shall be used
 - a. 36" wide thru 71" wide (self-closing)
 - b. 72" wide thru 96" wide (barrel)
- l. Strength: Assembled sections should be able to support a minimum of 1,100 pounds of vertical load at the mid-point of any horizontal rail without permanent deformation

PART III – EXECUTION

A. Surface Conditions

- 1. Examine the areas and conditions under which work of this section will be performed. Correct conditions detrimental to timely and proper completion of work. Do not proceed until unsatisfactory conditions are corrected.

B. Installation

- 1. Follow manufacturer's instructions for the installation of all gates and fencing.
- 2. All material must be checked upon receipt at the job site prior to installation to check for damage that may have occurred during transport. The fence system must be stored in a safe place and dry environment so as to protect it from any potential damage. The fence system must be installed with manufacturer's standard procedures.

C. Setting Posts

- 1. Remove loose and foreign materials from sites and bottoms of holes and moisten soil prior to pouring concrete. Center and align posts in holes. Place concrete around posts in a continuous pour and vibrate or tamp for consolidation.
- 2. Check each post for vertical and top alignment. Hold in position during placement and finishing operation. Trowel tops of footings and slope or dome to direct water away from posts.
- 3. Set keeps, stops, sleeves and other accessories into concrete as required. Keep exposed concrete surfaces moist for at least seven days after placement, or cure with a membrane curing material. Grout-in those parts with are set into sleeved holes, concrete constructions or rock excavations using non-shrink Portland cement grout.

D. Installing Gates

- 1. Install gates plumb, level and secure for full opening without interference. Install ground-set items in concrete for anchorage in accordance with manufacturer's recommendations as approved by the architect. Lubricate and adjust the hardware for smooth operation.

VII. TECHNICAL SPECIFICATIONS – PVC COATED STEEL CHAIN LINK FENCE FABRIC AND GATES

PART I – GENERAL

A. DESCRIPTION

1. Furnish and install PVC coated steel chain link fence fabric and gates as indicated on the drawings and as specified. Include all labor, materials, equipment, and transportation to furnish and install a galvanized chain link fence system and gates. The work includes, but is not limited to fences, gates and related hardware.

B. QUALITY ASSURANCE

1. STANDARDS

- a. ASTM B 6 Slab Zinc
- b. ASTM F567 Installation of Chain Link Fence
- c. ASTM F668 Poly (Vinyl Chloride) (PVC) and Other Organic Polymer Coated Steel Chain Link Fence Fabric, Class 1
- d. Federal Specification RR-F-19 1 K/1 D Fencing, Wire and Post Metal (Chain-Link Fence Fabric), Type IV

C. PERFORMANCE REQUIREMENTS

1. Delegated Design: Design PVC- coated steel chain link fence fabric and gates, including comprehensive engineering analysis by a qualified engineer, using performance requirements and design criteria indicated.
2. Structural Performance: PVC- coated steel chain link fence fabric and gate framework shall withstand the effects of gravity loads and the following stresses within limits and under conditions indicated according to applicable codes.

D. SUBMITTALS

1. Product Data - for each type of product indicated include construction details, material descriptions, dimensions of individual components and profiles, and finishes for chain link fences and gates.
2. Shop Drawings
 - a. Shop drawings in sufficient detail to show fabrication, anchorage and interface of the work. Include plan layout, accessories, fittings, and hardware (excluding items not in contract).
 - b. Include plans, elevations, sections, details, and attachment to other work. Show accessories, hardware, gate operation, and operational clearances.
3. Samples for verification: Prepared on sample size indicated below
4. Product Certificates: For each type of chain link fence from manufacturer
5. Product Test Reports: For framing strength
6. Warranty: Sample of Special Warranty

E. QUALITY ASSURANCE

1. Emergency Access Requirements: Comply with requirements of local authority having jurisdiction for gates with panic hardware and closers serving a required means of access.

F. PROJECT CONDITIONS

1. Field Measurement: Verify layout information for chain link fences and gates shown on drawings in relation to property survey and existing structures. Verify dimensions by field measurements.

G. WARRANTY

1. Extruded PVC coated steel chain link fence fabric is warranted for 15 years against failure due to rust or corrosion.

H. PERMITTING

1. Any fence 7' or greater in height requires permitting through LCS Code Enforcement (<https://www.leonschools.net/Domain/6096>)

PART II – PRODUCTS: PVC- COATED STEEL CHAIN LINK FENCING FABRIC

A. MANUFACTURERS – ONGUARD CHAIN LINK FENCE

1. STEPHENS PIPE & STEEL, LLC.
300 Bowman Mill Rd SE
Winder, GA 30680
(877) 868-5518 / (770) 868-1800
Fax: (770) 868-1809
Branch Managers: Bill Dickert
2. Or Approved Equal

B. SPSV EXTRUDED POLY - PVC COATED STEEL CHAIN LINK FENCE FABRIC

Extruded fabric shall be vinyl coated, high strength galvanized steel, chain link fence fabric for industrial, commercial and institutional application. Extruded fabric shall be the highest quality available.

1. **COMPOSITION AND MATERIALS** - The galvanized steel core wire for producing fused PVC coated steel chain link fence fabric shall be produced by cold drawing good commercial grade steel rod into wire of the appropriate diameter. The steel rod from which the wire is drawn shall be produced by the open hearth, electric furnace or basic oxygen process. The galvanized coating shall be produced by passing the cleaned wire through a bath of molten zinc which conforms to ASTM B6.
2. **CHAIN LINK FENCE FABRIC** - The base metal of the chain link fence fabric shall be composed of commercial quality, medium-carbon galvanized (zinc coated) steel wire. The vinyl coating shall be extruded to galvanized steel wire. Vinyl coating thickness, galvanized coating weight, and wire tensile strength shall conform to Federal Specification RR-F-191, ASTM F668, and Class 1. The wire shall be PVC coated before weaving and shall be free and flexible at all joints. Unless otherwise specified, fabric woven in 2 in. (50 mm) mesh, under 72" (1,830 mm) in height, shall be knuckled at both selvages; fabric 72" (1,830mm) high and over shall be knuckled at one selvage and twisted at the other. All fabrics woven into meshes under 2 in. (50 mm) shall have both selvages knuckled.
3. **WIRE DIAMETER** - Core wire sizes shall be 9 gauge core.
4. **WIRE COATING** - Only plasticized poly (vinyl chloride) (PVC) with a low temperature (-20 °C; -4°F) plasticizer and no extenders or extraneous matter other than the necessary stabilizers and pigments, shall be used.
5. **ASTM COLOR SYSTEM** - Standard colors shall conform to ASTM F934 and include:

Green	Brown	Black
28.61	27.76	22.30
-12.59	3.37	-0.09
1.95	4.28	-0.85

6. **COATING ADHESION** - The PVC coated wire shall pass the test for adhesion contained in ASTM F668 for Class 1 chain link fabric.

PART III – EXECUTION

A. SURFACE CONDITIONS

1. Examine the areas and conditions under which work of this section will be performed. Correct conditions detrimental to timely and proper completion of work. Do not proceed until unsatisfactory conditions are corrected.

B. INSTALLATION

1. Follow manufacturer’s instructions for the installation of all gates and fencing.
2. All material must be checked upon receipt at the job site prior to installation to check for damage that may have occurred during transport. The fence system must be stored in a safe place and dry environment so as to protect it from any potential damage. The fence system must be installed with manufacturer’s standard procedures.
3. If PVC coating is damaged during installation, contractor must replace or repair the material at own expense.

C. SETTING POSTS

1. Remove loose and foreign materials from sites and bottoms of holes and moisten soil prior to pouring concrete. Center and align posts in holes. Place concrete around posts in a continuous pour and vibrate or tamp for consolidation.
2. Check each post for vertical and top alignment. Hold in position during placement and finishing operation. Trowel tops of footings and slope or dome to direct water away from posts.
3. Set keeps, stops, sleeves and other accessories into concrete as required. Keep exposed concrete surfaces moist for at least seven days after placement, or cure with a membrane curing material. Grout-in those parts with are set into sleeved holes, concrete constructions or rock excavations using non-shrink Portland cement grout.

D. INSTALLING GATES

1. Install gates plumb, level and secure for full opening without interference. Install ground-set items in concrete for anchorage in accordance with manufacturer's recommendations as approved by the architect. Lubricate and adjust the hardware for smooth operation.

E. PERMITTING

1. Any fence 7' or greater in height requires permitting through LCS Code Enforcement (<https://www.leonschools.net/Domain/6096>)

VIII. TECHNICAL SPECIFICATIONS – CHAIN LINK FENCING FABRIC (ALL HEIGHTS)

PART I – GENERAL

A. DESCRIPTION

1. Base metal of the fabric shall be a good commercial quality steel wire of number nine gauge. The fabric shall withstand the breaking load of one thousand two hundred ninety (1,290) pounds.
2. The fabric shall be zinc-coated weaving with a minimum 2.0 oz. of zinc per square foot of surface area and conform to ASTM A-392, Class II. The zinc used for the coating shall conform to the grades specified in ASTM Designation B6-B8 for Slab Zinc (Seltzer).
3. The fabric shall be nine (9) gauge with a mesh size of two (2) inches and a diameter of .1483.
4. Fabric height shall vary according to the project coordinator's request.
5. The fabric shall be made of high-grade materials utilizing excellent workmanship. The zinc coating shall be applied in a continuous process and shall not be applied to the fabric in roll form. Excessive roughness, blisters, sal ammoniac spots, bruising and flaking shall be noted. These and other obvious defects, if present, shall provide a basis for product rejection.

B. POST

1. End and pull post shall be standard weight, schedule forty (40) piping. Weight of material shall be in accordance with the diameter per foot. Plans should clearly identify location of intermediate pull post.
2. Line post shall be standard weight, schedule forty (40) piping. Weight of material shall be in accordance with diameter. Post shall be a maximum of 10'0" on center.
3. All post shall be zinc coated after fabrication, using zinc grade "E" in accordance with Federal Specifications 00-Z-351. Weight of coating per square foot of actual surface area shall average not less than 1.2 ounces.
4. All posts that are installed in walkways and anchored to walls shall be anchored using the appropriate size anchoring devices.

C. TOP RAIL

1. Top Rails shall be standard weight, schedule forty (40) piping in lengths into a continuous run. Couplings shall not be less than six (6) inches long, with 0.70 minimum wall thickness and shall allow for expansion and contraction of the rail. Suitable ties or clips shall be provided in sufficient number for attaching the fabric securely to the top rail at intervals between six and eight (6" – 8") inches apart. Means shall be provided for attaching the top rail to each pull and end post. The top rail shall be zinc

coated after fabrication, using zinc grade "E" in accordance with Federal Specifications 00-Z-351. Weight of material shall be 2.28 pounds per foot.

D. POST BRACES

1. Post braces shall be piping of standard weight, schedule forty (40) at all end bays. Plans should clearly specify locations of additional bracings at intermediate pull posts.

E. TENSION WIRE

1. Tension wire shall be spiraled wire, zinc coated of not less than number seven (7) gauge. Ties or clips shall be provided and installed for attaching each wire to the fabric at intervals not exceeding one (1) foot.

F. TIES AND BANDS

1. Ties and bands shall be adequate strength and in sufficient number to anchor fabric to post, top rail, tension wire and other locations. Steel ties and bands shall be required no more than nine - twelve (9" – 12") inches apart.

G. STRETCHER BARS

1. Stretcher bars shall be not less than 3/16" x 3/4" and shall be of lengths one (1) inch or less than full height of the fabric with which they are to be used. One stretcher bar shall be provided at each end post and each side of pull post. All material shall be zinc coated.

I. POST HOLES

1. Three (3) inch O.D. Post holes shall be twelve (12) inches in diameter and 4'0" deep
2. Two (2) inch O.D. Post holes shall be six (6) inches in diameter and 3'0" deep

I. CONCRETE

1. All concrete shall be two thousand (2,000) P.S.I. No calcium chloride shall be used without prior approval from the project coordinator in writing.

J. DIAMETER

1. The following diameter sizes shall be matched to the fabric height and shall comply with the weights and finishes as specified.

	Line Post	Terminal Post	Corner Post
4' 0" High	2" O.D.	3" O.D.	3" O.D.
5' 0" High	2" O.D.	3" O.D.	3" O.D.
6' 0" High	2" O.D.	3" O.D.	3" O.D.
10' 0" High	2 1/2" O.D.	3" O.D.	3" O.D.
12' 0" High	2 1/2" O.D.	3" O.D.	3" O.D.
	Pull Post	Gate Post	Top Rail
4' 0" High	3" O.D.	3" O.D.	1 5/8" O.D.
5' 0" High	3" O.D.	3" O.D.	1 5/8" O.D.
6' 0" High	3" O.D.	3" O.D.	1 5/8" O.D.
10' 0" High	3" O.D.	3" O.D.	1 5/8" O.D.
12' 0" High	3" O.D.	3" O.D.	1 5/8" O.D.

Braces (Corner and Intermediate)	
4' 0" High	1 5/8" O.D.
5' 0" High	1 5/8" O.D.
6' 0" High	1 5/8" O.D.
10' 0" High	1 5/8" O.D.
12' 0" High	1 5/8" O.D.

L. GATES (SWING OR ROLL GATES)

1. Gate frames shall be 1 5/8" standard weight schedule forty (40) piping with braces and shall have industrial (pressed steel) hinges.
2. Gate hardware: Fork latch with gravity drop for single gate. Center gate stop and drop rod for double gate; malleable heavy industrial box hinges, two per leaf, and hardware for padlock. **If 180 degree hinges are used, they must be adjusted properly and welded in place.**
3. When panic hardware is requested, an eighteen (18) inch wide, 3/8 inch plate shall be welded the full width of the gate for mounting of the panic hardware. Welds should be solid across both ends of plate. Also, an eighteen (18) inch latch plate shall be welded on terminal post. Installation of panic hardware shall require an upgrade of one (1) inch to terminal post. All shall be painted to match gate.

M. STEEL GATE (SWING)

1. The diameter sizes in item J shall be matched to the fabric height and shall comply with the weights and finishes as specified below:
 - a. Provide gate and frame replacing all aluminum elements with steel-prepared and finished with appropriate powder coating as noted below. NOTE: welded hinges to be revised to barrel hinge #44-2003 as provided by "King Architectural Metals" and install gap at 1 3/4" as required by manufacturer.
 - b. Coating – after appropriate pretreatment, aluminum members are to be dried and powder coating shall be applied meeting or exceeding the following criteria:
 - 1) AAMA 2605 specification
 - 2) 3,000 hr. of salt spray testing under ASTM B117
 - 3) Final color to be selected by LCS from standard color selections
 - c. Surrounding elements gate of vary per school campus and site condition – coordinate with LCS
 - d. Coordinate hardware with LCS

PART III – EXECUTION

A. SURFACE CONDITIONS

1. Examine the areas and conditions under which work of this section will be performed. Correct conditions detrimental to timely and proper completion of work. Do not proceed until unsatisfactory conditions are corrected.

B. INSTALLATION

1. All material must be checked upon receipt at the job site prior to installation to check for damage that may have occurred during transport. The fence system must be stored in a safe place and dry environment so as to protect it from any potential damage. The fence system must be installed with manufacturer's standard procedures.
2. Install framework, fabric, accessories and gates in accordance with ANSI/ASTM F567
3. Set intermediate terminal, gate and corner posts plumb, in concrete footings with top of footing 2" above finish grade. Slope top of concrete for water runoff
4. Footing depth below finish grade: ANSI/ASTM F567 two feet minimum
5. Brace each gate and corner post to adjacent line post with horizontal center brace rail and diagonal truss rods. Install brace rail, one bay from end and gate posts
6. Provide top rail through line post tops and splice with 6" long rail sleeves
7. Install center and bottom brace rail on corner gate leaves
8. Stretch fabric between terminal posts or at intervals of 100 feet maximum, whichever is less
9. Position bottom of fabric at 2" above finished grade
10. Fasten fabric to top rail, line posts, braces and bottom tension wire with tie wire at maximum 15" on centers.
11. Attach fabric to end, corner, and gate posts with tension bars and tension bar clips

12. Install bottom tension wire stretched taut between terminal posts
13. Install support arms sloped outward and attach barbed wire; tension and secure
14. **Do not** swing gate from building wall; provide gate posts
15. Install gate with fabric to match fence. Install three hinges per leaf, for six feet high and over, latch, catches, drop bolt, foot bolts and sockets, torsion spring retainer, retainer and locking clamp
16. Provide concrete center drop to footing depth and drop rod retainers at center of double gate openings.

IX. QUESTIONNAIRE AND RESPONSE

- A. PROPOSAL REQUIREMENTS:** Bidders must submit **one (1) original, five (5) copies and one (1) electronic copy (USB drive)** of their completed proposal. All proposals submitted in response to this RFP shall become the property of the District. Proposals should be sealed and mailed or hand delivered to: *Leon County Schools, Purchasing Department, Attn: June Kail, 3397 West Tharpe St., Tallahassee, Florida, 32303*

Proposals should not be excessively long or submitted in an elaborate format that includes expensive binders or graphics. Each page of the proposal should state the name of the bidder, the RFP number, and the page number. The District may request additional data or material to support proposals.

If any director, officer, employee, agent or other representative of a bidder, including any other parties that may be involved in a joint venture or a consortium with the bidder, makes, from and after the date of issuance of this RFP, any representation or solicitation to any member of the School Board or any official, employee or agent of the District, with the exception of, June Kail, Director of Purchasing with respect to the bidder's response or any other bidder's response, the District shall be entitled to reject that respondent's proposal. A representation for the purposes of this requirement can be considered to be anything said or written to any school board member, official, employee or agent which provides information advancing the interests of a proposal.

- B. PROPOSAL ORGANIZATION:** Your proposal is to be organized and submitted in the exact format as listed below:
1. Bidder Acknowledgement form (Page 1 of these specifications).
 2. RFP Identification Label affixed to your submittal (Page 2 of these specifications)
 3. Dispute Resolution Contact (pg. 6, item 23)
 4. Copies of the qualifier's Florida State license (pg. 11, item B, 1)
 5. Company information to include contact person, address, phone number, detailed statement of interest and qualifications to include but not limited to:
 - a. Financial responsibility to include years in business, form of business, i.e. proprietorship, corporation; changes in ownership; bank reference; any other information that details financial responsibility.
 - b. Number of employees along with their qualifications/certifications and years with your firm
 - c. A listing of current multi-year contracts of similar size and scope
 6. Experience of your company or firm with the services as stated in the scope of work of these specifications
 7. Letters of reference or similar testimonials from current and/or previous customers
 8. Any additional qualifications of the firm and/or any additional company information that you feel is pertinent to the District's evaluation of your proposal.
 9. Cost Proposal Form (pg. 24-27)
 10. Conflict of Interest Certificate (Exhibit A)
 11. Application for Vendor Status (Exhibit B)
 12. Request for Taxpayer ID Number & Certification (Exhibit C)
 13. Customer Reference Form (Exhibit D)
 14. Vendor Questionnaire (Exhibit E)

15. Drug Free Workplace Verification Form (Exhibit F)
 16. Certification Regarding Debarment (Exhibit G)
 17. Sworn Statement (Exhibit H)
 18. Affidavit for Claiming Local Purchasing Preference (Exhibit I)
- C. **DOCUMENTATION:** Bidder **must include in their proposal** all documentation that will be used during the course of this agreement. **Bidder in all cases shall be in a position to assure a timely completion of service to the District.** Bidder will be asked to commit to an acceptable response and turn-around time as a performance parameter to this agreement. Bidder will be audited during the contract to confirm that performance commitments are being met.



Cost Proposal Form

RFP No. 473-2022 Fencing Materials and Installation District Wide

Vendor Acknowledgment and Approval

I certify that this proposal is made without prior understanding, agreement or connection with any corporation, firm, or person submitting a proposal for the same materials, supplies or equipment, and in all respects fair and without collusion or fraud. The following information, including an authorized representative signature is required to be submitted with your proposal in order to be considered for evaluation and award. The person signing below acknowledges and agrees with all proposed information as submitted and has the authorization of the said company to enter into a contractual agreement with the School Board of Leon County for the purposes as proposed and as described herein. Please print and sign below where required.

Authorized Representative's Name/Title	Authorized Representative's Signature	Date	
Company's Name	Telephone Number	FAX Number	
Address	City	State	Zip Code
Area Representative	Telephone Number	FAX Number	

<i>Bidder should submit one (1) original, five (5) copies and one (1) electronic copy (USB drive)</i>					
ALUMINUM SECURITY FENCING					
Item No.	Height	Quantity	Price Per Linear Ft.	A. Corner Post	B. End Post
1.	4' 0"	0' – 100'	\$	\$	\$
2.	5' 0"	0' – 100'	\$	\$	\$
3.	6' 0"	0' – 100'	\$	\$	\$
4.	4' 0"	100' – 500'	\$	\$	\$
5.	5' 0"	100' – 500'	\$	\$	\$
6.	6' 0"	100' – 500'	\$	\$	\$
7.	4' 0"	500' - Above	\$	\$	\$
8.	5' 0"	500' - Above	\$	\$	\$
9.	6' 0"	500' - Above	\$	\$	\$
ALUMINUM SECURITY GATES					
10.	Swing Gate – Type "A" 48" h x 48" w		1 each	\$	
11.	Swing Gate – Type "B" 48" h x 48" w		1 each	\$	
12.	Swing Gate – Type "C" 48" h x 48" w		1 each	\$	
13.	Swing Gate – Type "A" 60" h x 60" w		1 each	\$	
14.	Swing Gate – Type "B" 60" h x 60" w		1 each	\$	
15.	Swing Gate – Type "C" 60" h x 60" w		1 each	\$	

16.	Swing Gate – Type “A” 72” h x 72” w		1 each	\$	
17.	Swing Gate – Type “B” 72” h x 72” w		1 each	\$	
18.	Swing Gate – Type “C” 72” h x 72” w		1 each	\$	
STEEL GATES WITH POWDER TO MATCH					
1.	Swing Gate – Type “A” 48” h x 48” w		1 each	\$	
2.	Swing Gate – Type “B” 48” h x 48” w		1 each	\$	
3.	Swing Gate – Type “C” 48” h x 48” w		1 each	\$	
4.	Swing Gate – Type “A” 60” h x 60” w		1 each	\$	
5.	Swing Gate – Type “B” 60” h x 60” w		1 each	\$	
6.	Swing Gate – Type “C” 60” h x 60” w		1 each	\$	
7.	Swing Gate – Type “A” 72” h x 72” w		1 each	\$	
8.	Swing Gate – Type “B” 72” h x 72” w		1 each	\$	
9.	Swing Gate – Type “C” 72” h x 72” w		1 each	\$	
BLACK/GREEN PVC COATED STEEL CHAIN LINK FENCE FABRIC					
Item No.	Height	Quantity	Price Per Linear Ft.	A. Corner Post	B. End Post
1.	4’ 0”	0’ – 100’	\$	\$	\$
2.	5’ 0”	0’ – 100’	\$	\$	\$
3.	6’ 0”	0’ – 100’	\$	\$	\$
4.	4’ 0”	100’ – 500’	\$	\$	\$
5.	5’ 0”	100’ – 500’	\$	\$	\$
6.	6’ 0”	100’ – 500’	\$	\$	\$
7.	4’ 0”	500’ - Above	\$	\$	\$
8.	5’ 0”	500’ - Above	\$	\$	\$
9.	6’ 0”	500’ - Above	\$	\$	\$
BLACK/GREEN VINYL PVC COATED STEEL CHAIN LINK FENCE FABRIC SECURITY GATES					
10.	Swing Gate – Type “A” 48” h x 48” w		1 each	\$	
11.	Swing Gate – Type “B” 48” h x 48” w		1 each	\$	
12.	Swing Gate – Type “C” 48” h x 48” w		1 each	\$	
13.	Swing Gate – Type “A” 60” h x 60” w		1 each	\$	
14.	Swing Gate – Type “B” 60” h x 60” w		1 each	\$	
15.	Swing Gate – Type “C” 60” h x 60” w		1 each	\$	
16.	Swing Gate – Type “A” 72” h x 72” w		1 each	\$	
17.	Swing Gate – Type “B” 72” h x 72” w		1 each	\$	
18.	Swing Gate – Type “C” 72” h x 72” w		1 each	\$	

CHAIN LINK FENCING

Item No.	Height	Quantity	Price per linear ft.	A. Corner & Pull Post	B. End & 3" Gate Post	C. Post Braces
1.	4' 0"	0' – 100'	\$	\$	\$	\$
2.	5' 0"	0' – 100'	\$	\$	\$	\$
3.	6' 0"	0' – 100'	\$	\$	\$	\$
4.	8' 0"	0' – 100'	\$	\$	\$	\$
5.	10' 0"	0' – 100'	\$	\$	\$	\$
6.	12' 0"	0' – 100'	\$	\$	\$	\$
7.	4' 0"	100' – 500'	\$	\$	\$	\$
8.	5' 0"	100' – 500'	\$	\$	\$	\$
9.	6' 0"	100' – 500'	\$	\$	\$	\$
10.	8' 0"	100' – 500'	\$	\$	\$	\$
11.	10' 0"	100' – 500'	\$	\$	\$	\$
12.	12' 0"	100' – 500'	\$	\$	\$	\$
13.	4' 0"	500' - Above	\$	\$	\$	\$
14.	5' 0"	500' - Above	\$	\$	\$	\$
15.	6' 0"	500' - Above	\$	\$	\$	\$
16.	8' 0"	500' - Above	\$	\$	\$	\$
17.	10' 0"	500' - Above	\$	\$	\$	\$
18.	12' 0"	500' - Above	\$	\$	\$	\$

CHAIN LINK GATES

19.	Single Swing Gate	1 each priced per linear ft.	\$ _____
20.	Double Swing Gate	1 each priced per linear ft.	\$ _____
21.	Rolling Gate	1 each priced per linear ft.	\$ _____

BLACK & GREEN CHAIN LINK FENCING

Item No.	Height	Quantity	Price per linear ft.	A. Corner & Pull Post	B. End & 3" Gate Post	C. Post Braces
1.	4' 0"	0' – 100'	\$	\$	\$	\$
2.	5' 0"	0' – 100'	\$	\$	\$	\$
3.	6' 0"	0' – 100'	\$	\$	\$	\$
4.	8' 0"	0' – 100'	\$	\$	\$	\$
5.	10' 0"	0' – 100'	\$	\$	\$	\$
6.	12' 0"	0' – 100'	\$	\$	\$	\$
7.	4' 0"	100' – 500'	\$	\$	\$	\$

Item No.	Height	Quantity	Price per linear ft.	A. Corner & Pull Post	B. End & 3" Gate Post	C. Post Braces
8.	5' 0"	100' – 500'	\$	\$	\$	\$
9.	6' 0"	100' – 500'	\$	\$	\$	\$
10.	8' 0"	100' – 500'	\$	\$	\$	\$
11.	10' 0"	100' – 500'	\$	\$	\$	\$
12.	12' 0"	100' – 500'	\$	\$	\$	\$
13.	4' 0"	500' - Above	\$	\$	\$	\$
14.	5' 0"	500' - Above	\$	\$	\$	\$
15.	6' 0"	500' - Above	\$	\$	\$	\$
16.	8' 0"	500' - Above	\$	\$	\$	\$
17.	10' 0"	500' - Above	\$	\$	\$	\$
18.	12' 0"	500' - Above	\$	\$	\$	\$
BLACK & GREEN CHAIN LINK GATES						
19.	Single Swing Gate	1 each priced per linear ft.		\$ _____		
20.	Double Swing Gate	1 each priced per linear ft.		\$ _____		
21.	Rolling Gate	1 each priced per linear ft.		\$ _____		
LABOR COST PROPOSAL						
1.	Chief Installer (each) rate for new installation during normal business hours Monday through Friday 7:30 a.m. to 5:30 p.m.			\$ _____	PER HR	
2.	Chief Installer (each) rate for new installation after normal business hours Monday through Friday 5:30 p.m. to 7:30 a.m.			\$ _____	PER HR	
3.	Laborer (each) rate for new installation during normal business hours Monday through Friday 7:30 a.m. to 5:30 p.m.			\$ _____	PER HR	
4.	Laborer (each) rate for new installation after normal business hours Monday through Friday 5:30 p.m. to 7:30 a.m.			\$ _____	PER HR	
MATERIALS MARKUP						
1.	Invoiced Cost Plus % Markup - for materials not listed on the cost proposal form. (The Board will not accept markup percentages in excess of 25% of the invoiced cost of the materials and equipment.)					_____ %

ADDENDA ACKNOWLEDGMENT: The undersigned also acknowledges the receipt of the following Addenda:

ADDENDUM NO. _____ **DATED** _____ **ADDENDUM NO.** _____ **DATED** _____

ADDENDUM NO. _____ **DATED** _____ **ADDENDUM NO.** _____ **DATED** _____

EXHIBIT A



CONFLICT OF INTEREST CERTIFICATE

Bidder **must** execute either Section I or Section II hereunder relative to Florida Statute 112.313(12). Failure to execute either section may result in rejection of this proposal.

SECTION I

I hereby certify that no official or employee of the School Board requiring the goods or services described in these specifications has a material financial interest in this company.

_____	_____
<i>Signature</i>	<i>Company Name</i>
_____	_____
<i>Name of Official (Type or print)</i>	<i>Business Address</i>

	<i>City, State, Zip Code</i>

SECTION II

I hereby certify that the following named Leon County School Board official(s) and employee(s) having material financial interest(s) (in excess of 5 %) in this company have filed Conflict of Interest Statements with the Supervisor of Elections, 315 South Calhoun Street, Tallahassee, Leon County, FL prior to bid opening.

Name	Title or Position	Date of Filing
_____	_____	_____
_____	_____	_____

_____	_____
<i>Signature</i>	<i>Company Name</i>
_____	_____
<i>Name of Official (Type or print)</i>	<i>Business Address</i>

	<i>City, State, Zip Code</i>



2757 West Pensacola Street – Tallahassee, FL 32304-2998
 FAX TO: (850) 487-7869 or EMAIL TO: MathisR@leonschools.net

APPLICATION FOR VENDOR STATUS
 (IRS W-9 Facsimile)

COMPANY NAME: _____ New Vendor Update

CONTACT PERSON: _____ **LCSB Employee:** YES NO

PHONE NUMBER: _____ **FAX NUMBER:** _____

CORRESPONDENCE ADDRESS: _____

CITY: _____ **STATE:** _____ **ZIP + 4:** _____

REMITTANCE INFORMATION
(if different from above)

CONTACT PERSON: _____

REMITTANCE ADDRESS: _____

CITY: _____ **STATE:** _____ **ZIP + 4:** _____

EMAIL ADDRESS: _____ **WEBSITE:** _____

PLEASE CHECK THE APPROPRIATE BOX:

PLEASE CHECK THE APPROPRIATE BOX: Individual/ Sole Proprietor S Corporation C Corporation Partnership
 Other _____ LLC – Type (Check one) C S P

TAX ID NUMBER: _____ or _____
 Federal Employer Identification Number Social Security Number

Section 6109 of the Internal Revenue Service Code requires you to provide your correct TIN to persons, businesses, or agencies that are required to file information returns with the IRS. Purchase orders will not be issued to vendors who fail to provide a TIN.

PLEASE INDICATE THE FOLLOWING:

***Minority Vendor?** Yes No **If yes, certification is required – (Please submit with form)*

Race: Caucasian Hispanic African American
 American Indian Asian Other: _____

Gender: Male Female

Signature _____ _____
Print Name _____ _____
Date

LCSB site contact requesting vendor: _____
Name Phone & Email

For LCSB Employee Use Only

Entered by: _____ Date entered: _____



Leon County Schools Authorization for ACH Direct Payment

Finance Department
2757 West Pensacola Street, Tallahassee, Florida 32304

Payee/Vendor Name: _____

Address: _____

City, State Zip: _____

Telephone: _____

Contact Name: _____

Contact E-mail: _____

Complete this section for new enrollments or for financial institution or account changes.

Select One: New Enrollment Financial Institution or Account Change

Bank Name _____

Branch *(if applicable)* _____

City, State, Zip _____

Transit/Routing Number _____

Bank Account Number _____

Account Type (check one) _____ Checking **OR** _____ Savings

Account Type (check one) _____ Personal **OR** _____ Business

Complete This Section To Cancel Your ACH Electronic Deposit Authorization

I, the undersigned, authorize Leon County Schools to deposit payments directly to the account indicated above and to correct any errors which may occur from the transactions. I also authorize the financial institution named above to post these transactions to that account. This authorization will remain in force until Leon County Schools receives written notice of cancellation from me. I acknowledge that the origination of ACH transactions to my account must comply with the provisions of U.S. law.

Signature _____ Date _____

Name *(printed)* _____ Title _____

Mail the completed form to the address above or email to marschkak@leonschools.net

For LCS use only

Vendor Name _____ Date Received _____

EXHIBIT C



E-Verify Affidavit

- A. As of January 1, 2021, pursuant to Section 448.095, Florida Statutes, Contractor shall register with and use the U.S. Department of Homeland Security's E-Verify system to verify the work authorization status of all employees hired during the term of this Agreement and must, upon request, provide evidence of compliance with this provision.
B. Subcontractors:
1. As of January 1, 2021, Contractor shall also require all subcontractors performing work under this Agreement to use the E-Verify system for any employees they may hire during the term of this Agreement.
2. Subcontractors shall provide Contractor with an affidavit stating the subcontractor does not employ, contract with, or subcontract with an unauthorized alien, as stated in Section 448.095, Florida Statutes.
3. Contractor shall provide a copy of such affidavit to the School Board upon receipt and shall maintain a copy for the duration of the Agreement.
C. Failure to comply with this provision is a material breach of the Agreement, and School Board may choose to terminate the Agreement at its sole discretion. Contractor may be liable for all costs associated with School Board securing the same services, inclusive, but not limited to, higher costs for the same services.
D. It is the responsibility of the vendor/contractor to insure compliance with E-verify requirements (as applicable). To enroll in E-Verify, employers should visit the E-Verify website (http://www.uscis.gov/e-verify) and follow the instructions. The employer must retain the I-9 Forms for inspection. By affixing your signature below you hereby affirm that you will comply with E-Verify requirements.

Federal Employer Identification Number (FEIN): _____

Name: _____ Address: _____

Signature of Affiant Printed Name Date

State of: _____ County of: _____

The foregoing instrument was acknowledged before me, by means of [] physical presence or [] online notarization, this

_____ day of _____ 20 _____ by _____

who is personally known to me [] or has produced identification []. Type of identification produced: _____

Notary Signature

Commission Expires

SEAL

Notary Printed Name

EXHIBIT D



CUSTOMER REFERENCE FORM

RFP NO. 473-2022 Fencing Materials and Installation District Wide

Please provide all requested information for each reference.

Company Name: _____

Business Type: _____

Contact Person: _____

Telephone: _____

Email: _____

Date Last Supplied Products or Services: _____

Company Name: _____

Business Type: _____

Contact Person: _____

Telephone: _____

Email: _____

Date Last Supplied Products or Services: _____

Company Name: _____

Business Type: _____

Contact Person: _____

Telephone: _____

Email: _____

Date Last Supplied Products or Services: _____

EXHIBIT E



VENDOR QUESTIONNAIRE

RFP NO. 473-2022 Fencing Materials and Installation District Wide

Please provide written responses to the following questions. If the answer to any of the questions is `Yes`, Vendor shall describe fully the circumstances, reasons therefore, the current status, and ultimate disposition of each matter that is the subject of this inquiry.

1. Has Vendor been declared in default of any contract?
 Yes No

2. Has Vendor forfeited any payment of performance bond issued by a surety company on any contract?
 Yes No

3. Has an uncompleted contract been assigned by Vendor's surety company on any payment of performance bond issued to Vendor arising from its failure to fully discharge all contractual obligations there under?
 Yes No

4. Within the past three years, has Vendor filed for reorganization, protection from creditors, or dissolution under the bankruptcy statutes?
 Yes No

5. Is Vendor now the subject of any litigation in which an adverse decision might result in a material change in the firm's financial position or future viability?
 Yes No

6. Is Vendor currently involved in any state of a fact-finding, negotiations, or resistance to a merger, friendly acquisition, or hostile take-over, either as a target or as a pursuer?
 Yes No

7. Within the next year, does Vendor plan any personnel reductions? If so, explain by attachment.
 Yes No

8. Within the next year, does Vendor plan any divestments? If so, explain by attachment.
 Yes No



DRUG FREE WORKPLACE

Preference shall be given to vendors submitting a certification with their bid/proposal certifying they have a drug-free workplace in accordance with Section 287.087, Florida Statutes. Whenever two or more proposals that are equal with respect to price, quality, and service are received by the State or by any political subdivision for the procurement of commodities or contractual services, a proposal received from a business that certifies that it has implemented a drug-free workplace program shall be given preference in the award process. Established procedures for processing tie bids will be followed if none of the tied vendors have a drug-free workplace program. In order to have a drug-free workplace program, a business shall:

IDENTICAL TIE BIDS – Preference shall be given to businesses with drug-free workplace programs. Whenever two or more bids, which are equal with respect to price, quality, and service, are received by the State or any political subdivision for the procurement of commodities or contractual services, a bid received from a business that certifies that it has implemented a drug-free workplace program shall be given preference in the award process. Established procedure for processing tie bids shall be followed if none of the tied vendors have a drug-free workplace program.

A business shall:

- 1) Publish a statement notifying employees that the unlawful manufacture, distribution, dispensing, possession, or use of a controlled substance is prohibited in the workplace and specifying the actions that will be taken against employees for violations of such prohibition.
- 2) Inform employees about the dangers of drug abuse in the workplace, the business’s policy of maintaining a drug-free workplace, any available drug counseling, rehabilitation, and employee assistance programs, and the penalties that may be imposed upon employees for drug abuse violations.
- 3) Give each employee engaged in providing the commodities or contractual services that are under bid a copy of the statement specified in subsection (1).
- 4) In the statement specified in subsection (1), notify the employees that, as a condition of working on the commodities or contractual services that are under bid, the employee s will abide by the terms of the statement and will notify the employer of any conviction of, or plea of guilty or nolo contendere to, any violation of Chapter 893 or of any controlled substance law of the United States or any state, for a violation occur ring in the workplace no later than five (5) days after such conviction.
- 5) Impose a sanction on, or require the satisfactory participation in a drug abuse assistance or rehabilitation program if such is available in the employee’s community, by any employee who is so convicted.
- 6) Make a good faith effort to continue to maintain a drug-free workplace through implementation of this section.

As the person authorized to sign the statement, I certify that this firm complies fully with the above requirements.

VENDOR’S SIGNATURE: _____



**CERTIFICATION REGARDING DEBARMENT, SUSPENSION, INELIGIBILITY
AND VOLUNTARY EXCLUSION -LOWER TIER COVERED TRANSACTIONS**

(BEFORE COMPLETING CERTIFICATION, READ INSTRUCTIONS ON THE FOLLOWING PAGE)

1. The prospective lower tier participant certifies, by submission of this proposal, that neither it nor its principals is presently debarred, suspended, proposed for debarment, declared ineligible, or voluntarily excluded from participation in this transaction by any Federal department or agency.
2. Where the prospective lower tier participant is unable to certify to any of the statements in this certification, such prospective participant shall attach an explanation to this proposal.

_____ Organization Name	_____ PR/Award Number or Project Name
_____ Name(s) of Authorized Representative(s)	_____ Title(s) of Authorized Representative(s)
_____ Signature(s)	_____ Date

INSTRUCTIONS FOR CERTIFICATION OF DEBARMENT

1. By signing and submitting this form, the prospective lower tier participant is providing the certification set out on the reverse side in accordance with these instructions.
2. The certification in this clause is a material representation of fact upon which reliance was placed when this transaction was entered into. If it is later determined that the prospective lower tier participant knowingly rendered an erroneous certification, in addition to other remedies available to the Federal Government, the department or agency with which this transaction originated may pursue available remedies, including suspension and/or debarment.
3. The prospective lower tier participant shall provide immediate written notice to the person to whom this proposal is submitted if at any time the prospective lower tier participant learns that its certification was erroneous when submitted or has become erroneous by reason of changed circumstances.
4. The terms "covered transaction," "debarred," "suspended," "ineligible," "lower tier covered transaction," "participant," "person," "primary covered transaction," "principal," "proposal," and "voluntarily excluded," as used in this clause, have the meanings set out in the Definitions and Coverage sections of rules implementing Executive Order 12549. You may contact the person to which this proposal is submitted for assistance in obtaining a copy of those regulations.
5. The prospective lower tier participant agrees by submitting this form that, should the proposed covered transaction be entered into, it shall not knowingly enter into any lower tier covered transaction with a person who is debarred, suspended, declared ineligible, or voluntarily excluded from participation in this covered transaction, unless authorized by the department or agency with which this transaction originated.
6. The prospective lower tier participant further agrees by submitting this form that it will include this clause titled "Certification Regarding Debarment, Suspension, Ineligibility and Voluntary Exclusion -Lower Tier Covered Transactions," without modification, in all lower tier covered transactions and in all solicitations for lower tier covered transactions.
7. A participant in a covered transaction may rely upon a certification of a prospective participant in a lower tier covered transaction that it is not debarred, suspended, ineligible, or voluntarily excluded from the covered transaction, unless it knows that the certification is erroneous. A participant may decide the method and frequency by which it determines the eligibility of its principals. Each participant may, but is not required to, check the Nonprocurement List.
8. Nothing contained in the foregoing shall be construed to require establishment of a system of records in order to render in good faith the certification required by this clause. The knowledge and information of a participant is not required to exceed that which is normally possessed by a prudent person in the ordinary course of business dealings.
9. Except for transactions authorized under paragraph 5 of these instructions, if a participant in a covered transaction knowingly enters into a lower tier covered transaction with a person who is suspended, debarred, ineligible, or voluntarily excluded from participation in this transaction, in addition to other remedies available to the Federal Government, the department or agency with which this transaction originated may pursue available remedies, including suspension and/or debarment.

EXHIBIT H



**SWORN STATEMENT – NEW CONTRACTS
SWORN STATEMENT PURSUANT TO SECTION 1012.465,
FLORIDA STATUTES AS AMENDED BY
HB 1877, THE JESSICA LUNSFORD ACT**

***THIS FORM MUST BE SIGNED AND SWORN TO IN THE PRESENCE OF
A NOTARY PUBLIC OR OTHER OFFICIAL AUTHORIZED TO ADMINISTER OATHS.***

1. This sworn statement is submitted to The School Board of Leon County, Florida (*hereinafter "Board" or*

"School Board") by _____
(Print individual's name and title)

for _____
(Print name of entity submitting sworn statement)

whose business address is _____

and its Federal Employer Identification Number (FEIN) is _____
If the entity has no FEIN, include the Social Security Number (SSN) of the individual signing this sworn statement and so indicate.

2. I, _____ am duly authorized to make this sworn statement
(Print individual's name and title)

on behalf of: _____

(Print name of entity submitting sworn statement)

3. I understand that during the 2005 Legislative Session, House Bill 1877, The Jessica Lunsford Act (*hereinafter "The Act" or "Act"*) was passed and approved by Governor Bush on May 2, 2005, with an effective date of September 1, 2005.

4. I understand that the Act amends the background screening requirements of section 1012.465, Florida Statutes (2004) for all non-instructional school district employees or **"contractual personnel"** by requiring all non-instructional school district employees or contractual personnel who are permitted access on school grounds when students are present to undergo and pass "level 2 background screening," and further I understand the Act defines **"contractual personnel"** to include any vendor, individual, or entity under contract with the Board.

5. I understand that pursuant to section 1012.465, Florida Statutes as amended by the Act, non-instructional school district employees or contractual personnel who are permitted access on school grounds when students are present, who have direct contact with students or who have access to or control of school funds must meet level 2 screening requirements as described in sections 1012.32 and 435.04, Florida Statutes.

6. I understand that as a _____ (eg. a charter bus company)

 (Type of entity)
 all contractual personnel, as defined in section 1012.465, Florida Statutes, must meet Level 2 screening requirements as outlined in sections 1012.32 and 435.04, Florida Statutes in order to do business with the School Board.
7. I understand that “level 2 screening requirements” as defined in sections 1012.32 and 435.04, Florida Statutes means that fingerprints of all contractual personnel must be obtained and submitted to the Florida Department of Law Enforcement for state processing and to the Federal Bureau of Investigation for federal processing.
8. I understand that the School Board has implemented Board Policy 2.021 to comply with level 2 screening requirements, as defined in sections 1012.32 and 435.04, Florida Statutes. I understand that my company must comply with these local procedures as they are developed or amended from time to time.
9. I understand that any costs and fees associated with the required background screening will be borne by my company.
10. I understand that any personnel of the contractor found through fingerprint processing and subsequent level 2 background screening to have been found guilty of, regardless of adjudication, or entered a plea of nolo contendere or guilty to any offense outlined in Section 435.04, Florida Statutes (or any similar statute of another jurisdiction), **shall not be permitted** to come onto school grounds or any leased premises where school-sponsored activities are taking place when students are present, shall not be permitted direct contact with students, and shall not be permitted to have access to school district funds.
11. I understand that the failure of any of the company’s or my affected personnel to meet level 2 screening standards as required by section 1012.465, Florida Statutes, may disqualify my company from doing business with the School Board.
12. I hereby certify that the foregoing statement is true and correct in relation to the company for which I am submitting this sworn statement. I further certify that this statement is being given knowingly and voluntarily by me on behalf of my company.

The company submitting this sworn statement agrees to be bound by the provisions of SECTIONS 1012.32, 1012.465, AND 435.04 OF THE FLORIDA STATUTES AS AMENDED BY HB 1877, THE JESSICA LUNSFORD ACT 2005.

I CERTIFY THAT THE SUBMISSION OF THIS FORM TO THE SCHOOL BOARD OF LEON COUNTY, FLORIDA ON BEHALF OF THE COMPANY IDENTIFIED IN PARAGRAPH ONE (1) ABOVE BINDS THE COMPANY TO FULLY COMPLY WITH THE BACKGROUND SCREENING REQUIREMENTS OF SECTIONS 1012.32, AND 435.04, FLORIDA STATUTES.

 (Signature)



Sworn to and subscribed before me this _____ day of _____ 20____ .

_____ is personally known to me OR produced identification

by showing _____
 (Type of Identification)

Notary Public – State of _____ My commission expires on: _____

 Signature of Notary Public

 (Printed, typed or stamped commissioned name of Notary Public)

EXHIBIT I



AFFIDAVIT FOR CLAIMING LOCAL PURCHASING PREFERENCE

RFP NO. 473-2022 Fencing Materials and Installation District Wide

Proposer/Bidder/Quoter/Supplier affirms that it is a local or adjacent county business as defined by Policy #6450 of Leon County Schools and the regulations thereto.

A Leon/adjacent county vendor is a private independent vendor that has been licensed for at least six (6) months preceding the bid or proposal opening, as required by local, State, and Federal law to provide the goods, services, or construction to be purchased. The vendor must have a physical business address, staffed by at least one (1) person, in the geographical boundaries of Leon County or in the adjacent counties of Gadsden, Jefferson, or Wakulla, Florida. The vendor, on a day-to-day basis, should provide to the School Board the needed goods and/or services substantially from the local business address. Post Office boxes are not verifiable and shall not be used for the purpose of establishing said physical address.

Please complete the following in support of the self-certification:

Business Name: _____

Address: _____

_____ Phone _____ Fax _____ Email _____

County: _____ Length of time at this location: _____ # of employees at this location _____

Is your business certified as a small business through Leon County Schools? _____

_____ Signature of Authorized Representative _____ Date _____

State of FLORIDA
County of _____

Sworn to and subscribed before me, a Notary Public for the above State and County, on this _____ day of _____, 20 _____.

_____ Notary Public _____ My Commission Expires _____



INDEMNIFICATION AND INSURANCE

In consideration of this Contract, if awarded, the Vendor agrees without reservation to the indemnification and insurance clauses contained herein. These clauses are attached to and form a part of **RFP NO. 473-2022 Fencing Materials and Installation District Wide**.

Each party agrees to be fully responsible for its acts of negligence or its agents' acts of negligence when acting within the scope of their employment and agrees to be liable for any damages resulting from said negligence to the extent allowable pursuant to **Section 768.28, Florida Statutes**. Nothing herein is intended to serve as a waiver of sovereign immunity by the School Board. Nothing herein shall be construed as consent by the School Board to be sued by third parties in any matter arising out of any contract. Bidder shall hold harmless and defend the School Board and its agents and employees from all suits and actions, including attorney's fees and all costs of litigation and judgments of any name and description arising out of or incidental to the performance of this contract or work performed there under. This provision shall also pertain to any claims brought against the School Board by an employee of the named Bidder, any Subcontractor, or anyone directly or indirectly employed by any of them. The bidder's obligation under this provision shall not be limited in any way by the agreed upon contract price as shown in this Contract or the bidder's limit of, or lack of, sufficient insurance protection.

INSURANCE

Prior to being recommended for award, the Vendor has five business days after notification to submit proof of insurance as required herein. Failure to submit a fully completed certificate of insurance signed by an authorized representative of the insurer providing such insurance coverage's may cause the Vendor to be considered non-responsive and not eligible for award of the Contract. The insurance coverage's and limits shall meet, at a minimum, the following requirements:

1. Commercial General Liability Insurance in an amount not less than \$1,000,000 combined single limit per occurrence for bodily injury and property damage.
2. Automobile Liability Insurance covering all owned, non-owned and hired vehicles used in connection with the operation of the Vendor, in an amount not less than \$1,000,000 combined single limit per occurrence for bodily injury and property damage.
3. Workers' Compensation Insurance for all employees of the Vendor as required by Florida Statutes.
4. The School Board of Leon County, Florida" must be listed as additional insured on all liability coverage's except Workers' Compensation.

The insurance coverage required shall include those classifications, as listed in standard liability insurance manuals, which most nearly reflect the operations of the Vendor.

All insurance policies shall be issued by companies with either of the following qualifications:

1. The company must be:
 - a. authorized by subsisting certificates of authority by the Department of Insurance of the State of Florida or
 - b. an eligible surplus lines insurer under Florida Statutes. In addition, the insurer must have a Best's Rating of "A" or better and a Financial Size Category of "IV" or better according to the latest edition of Best's Key Rating Guide, published by A.M. Best Company.

or

2. With respect only to the Workers' Compensation insurance, the company must be:
 - a. authorized as a group self-insurer pursuant to Florida Statutes or
 - b. authorized as a commercial self-insurance fund pursuant to Florida Statutes

Neither approval nor failure to disapprove the insurance furnished by the Vendor to the School Board shall relieve the Vendor of the Vendor's full responsibility to provide insurance as required by this Contract.

The Vendor shall be responsible for assuring that the insurance remains in force for the duration of the contractual period; including any and all option years that may be granted to the Vendor. The certificate of insurance shall contain the provision that the School Board be given no less than thirty (30) days written notice of cancellation. If the insurance is scheduled to expire during the contractual period, the Vendor shall be responsible for submitting new or renewed certificates of insurance to the School Board at a minimum of thirty (30) calendar days in advance of such expiration. Unless otherwise notified, the certificate of insurance **must be delivered to the following address: Leon County School Board Purchasing Department / Attn: June Kail, Director of Purchasing /3397 W. Tharpe St. / Tallahassee, Florida 32303.**

The name and address of the Leon County School Board, as shown directly below, must be listed as Certificate Holder on the Certificate of Insurance as well as clearly noted as "Additional Insured".

**Leon County School Board
2757 W. Pensacola St.
Tallahassee, FL 32304**

***The Vendor may be in default of this Contract for failure to maintain the insurance as required by this Contract.
Any questions and/or inquiries should be directed to Tod Stupski at (850) 561-8359.***



WORK ORDER FORM

RFP NO. 473-2022 Fencing Materials and Installation District Wide

- 1. Work Order Number: _____
- 2. Project Name: _____
- 3. Location Address: _____

- 4. Scope of Services *(attach additional pages as needed)*: _____

- 5. Board Contact: _____ Phone: _____
- 6. Estimated Number of Project Days: _____
- 7. Estimated Start Date: _____ Completion Date: _____
- 8. Estimated Cost *(attach additional pages as needed with detailed cost breakdown)*:
 - Total Labor: \$ _____
 - Total Materials/Supplies *(cost + markup)*: \$ _____
(Detailed breakdown to include itemization of cost with calculation of markup amount)
 - Total Inspection Fee *(as applies)*: \$ _____
 - Other *(subject to approval)*: \$ _____
- 9. Attachments Included *(circle one)*: YES NO

10. As agreed upon between Contractor and Board:

Contractor Name/Signature _____ Date: _____

As written/Title: _____

Contractor Name/Signature: _____ Date: _____

As written/Title: _____

Exhibit L – Address/Phone Listing of District School Sites

Cost Center	School Site	Phone	Cost Center	School Site	Phone
0441	Apalachee Elementary 650 Trojan Trail, 32311	488-7110	0401	Astoria Park Elementary 2465 Atlas Road, 32303	488-4673
1181	Bond Elementary 2204 Saxon Street, 32310	488-7676	0521	Buck Lake Elementary 1600 Pedrick Road, 32317	488-6133
1161	Canopy Oaks Elementary 3250 Pointview Drive, 32303	488-3301	0491	Chaires Elementary 4774 Chaires Crossroads, 32317	878-8534
1202	Conley Elementary School 2400 E. Orange Ave., 32311	414-5610	0511	DeSoto Trail Elementary 5200 Tredington Park Dr., 32309	488-4511
0561	Ft. Braden K-8 15100 Blountstown Hwy, 32310	488-9374	0381	Gilchrist Elementary 1301 Timberlane Road, 32312	893-4310
0041	Hartsfield Elementary 1414 Chowkeebin Nene, 32301	488-7322	1131	Hawks Rise Elementary 205 Meadow Ridge, 32312	487-4733
0481	Killlearn Lakes Elementary 8037 Deerlake East, 32312	893-1265	0421	Moore Elementary 1706 Dempsey Mayo Rd, 32308	877-6158
0171	Oak Ridge Elementary 4530 Shelfer Road, 32305	488-3124	0311	Pineview Elementary 2230 Lake Bradford Rd, 32310	488-2819
0231	Riley Elementary 1400 Indiana Street, 32304	488-5840	1171	Roberts Elementary 5777 Centerville Road, 32309	488-0923
0091	Ruediger Elementary 526 W. Tenth Ave., 32303	488-1074	0071	Sabal Palm Elementary 2813 Ridgeway Street, 32310	488-0167
0431	Sealey Elementary 2815 Allen Road, 32312	488-5640	0501	Springwood Elementary 3801 Fred George Road, 32303	488-6225
0031	Sullivan Elementary 927 Miccosukee Road, 32308	487-1216	0131	Woodville Elementary 9373 Woodville Highway, 32305	487-7043
0391	Belle Vue Middle 2214 Belle Vue Way, 32304	488-4467	0032	Cobb Middle 915 Hillcrest Ave., 32308	488-3364
0531	Deerlake Middle 9902 Deerlake W., 32312	922-6545	0451	Fairview Middle 3415 Zillah St., 32301	488-6880
0222	Griffin Middle 800 Alabama St., 32304	488-8436	1201	Montford Middle School 5789 Pimlico Drive, 32309	922-6011
0092	Raa Middle 401 W. Tharpe St., 32303	488-6287	0291	Nims Middle 723 W. Orange Ave., 32310	488-5960
1141	Chiles High 7200 Lawton Chiles Lane, 32312	488-1756	1151	Swift Creek Middle 2100 Pedrick Rd., 32317	487-4868
0021	Leon High 550 E. Tennessee St., 32308	488-1971	0161	Godby High 1717 W. Tharpe St., 32303	488-1325
0051	Rickards High 3013 Jim Lee Road, 32301	488-1783	1091	Lincoln High 3838 Trojan Trail, 32311	487-2110
0411	Gretchen Everhart 2750 Mission Rd., 32304	488-5785	0204	SAIL High 2006 Jackson Bluff Rd., 32304	488-2468
0191	Ghazvini Learning Center 860 Blountstown Hwy., 32304	488-2087	0361	Lively Technical Center 500 N. Appleyard Dr., 32304	487-7555
0361	Lively Aviation Center 3290 Capital Circle SW, 32310	488-2461			

Exhibit M– Listing of Additional District Facilities

Site Name	Site Address	Phone
Purchasing Dept.	3397 W. Tharpe St., 32303	488-1206
Property Management Warehouse	3374 W. Tharpe St. 32303	922-0657
Aquilina Howell Center	3955 W. Pensacola St., 32304	487-7893
Main Transportation Facility	440 Capital Circle N.W., 32304	488-2636
Transportation Bus Compound	536 Appleyard Drive, 32304	488-7572
Nutrition Service and Central Kitchen	3397 W. Tharpe St., 32303	488-7426
Main Administration Complex	2757 W. Pensacola St., 32304	487-7100
Early Childhood Development Center	500 N. Appleyard Dr., 32304	922-2099
Technology & Information Services	520 S. Appleyard Drive, 32304	488-7530
Materials and Stores	3360 W. Tharpe St., 32303	922-0657
Adult & Community Education	283 Trojan Trail, 32311	922-5343
Transportation Bus Compound	3601 Conner Blvd., 32311	922-6701
Transportation Bus Compound	601 Paul Russell Rd., 32301	922-6727
Academic Resource Center	526 Appleyard Dr., 32304	487-1957
Facilities and Maintenance	3420 W. Tharpe St., 32303	617-1777
Bloxham Building	727 South Calhoun St., 32301	561-6563

EXHIBIT N – DRAWINGS (4 PAGES)

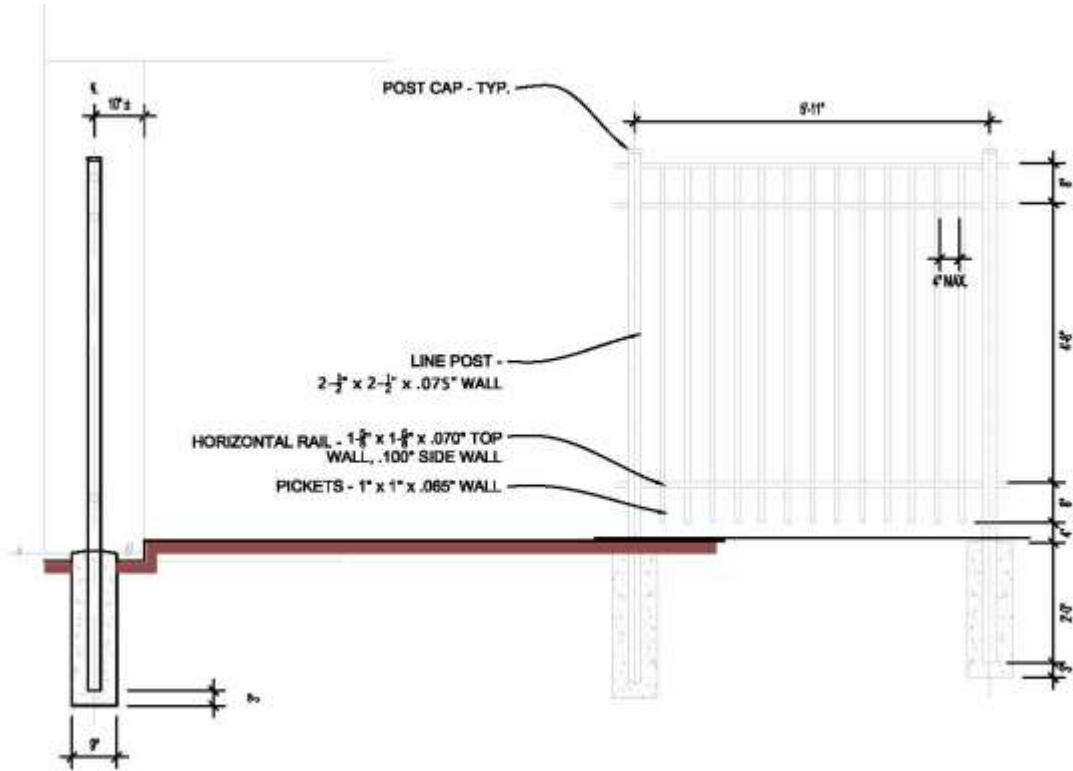

FENCE ELEVATION – TYPICAL

SCALE: 1/2" = 1'-0"

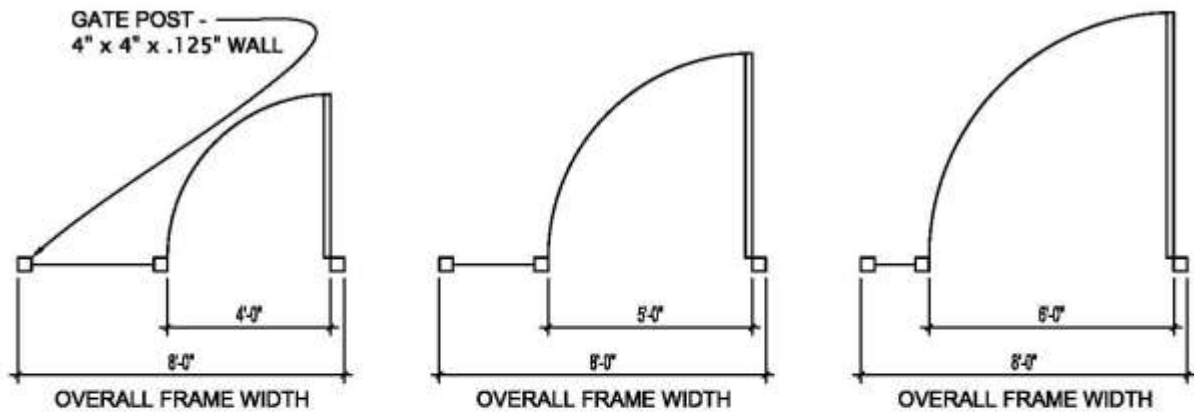

GATE FRAME – TYPICAL LAYOUT – 48", 60", & 72" GATES

SCALE: 1/2" = 1'-0"



FENCING & MATERIALS
INSTALLATION –
DISTRICT WIDE

LEON COUNTY SCHOOL BOARD
FACILITIES & CONSTRUCTION
3420 WEST THARPE STREET
TALLAHASSEE, FLORIDA 32303
(850) 617-5900

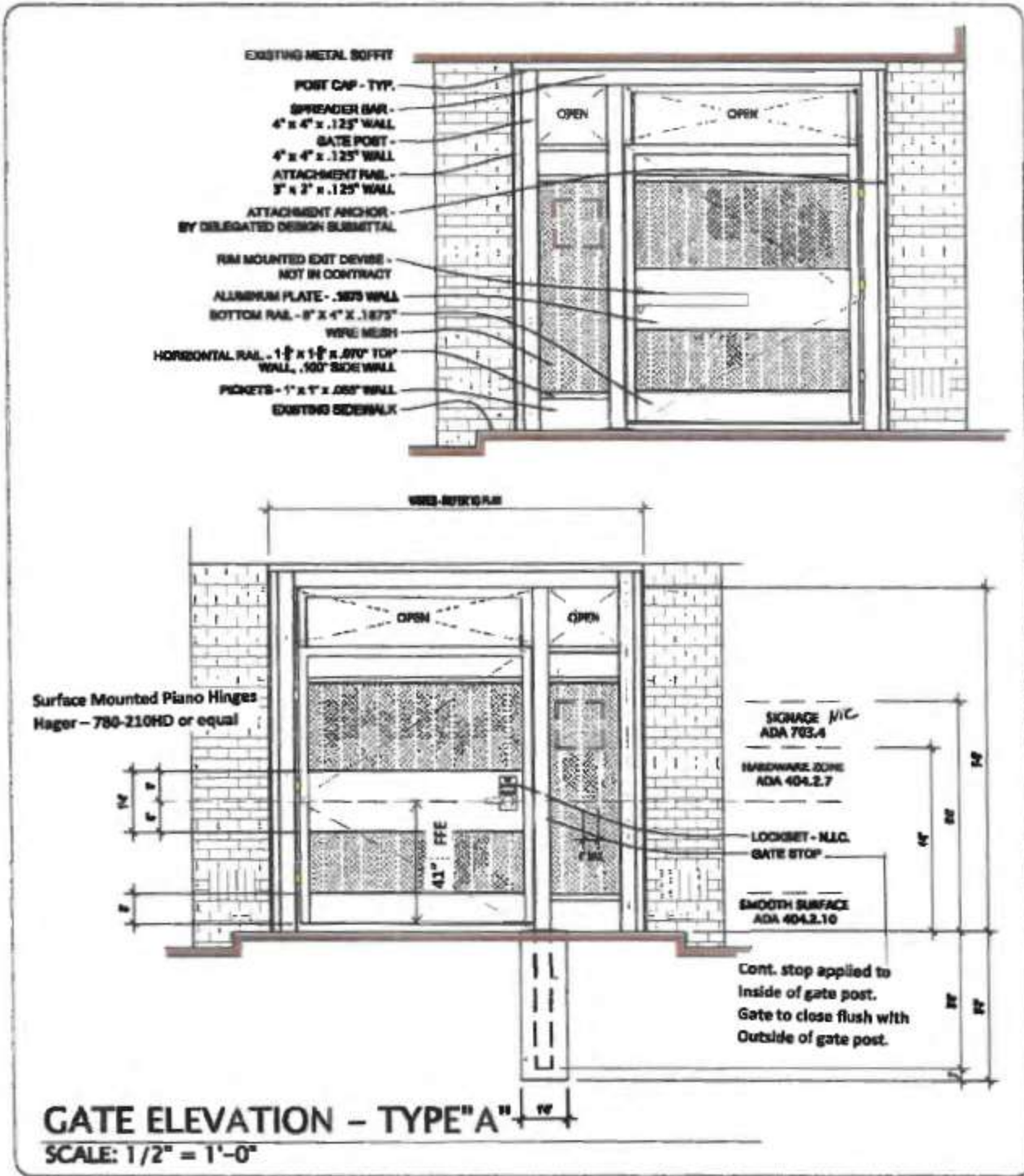

**FENCING & MATERIALS
INSTALLATION -
DISTRICT WIDE**

**LEON COUNTY SCHOOL BOARD
FACILITIES & CONSTRUCTION
3430 WEST THARPE STREET
TALLAHASSEE, FLORIDA 32309
(850) 617-5800**

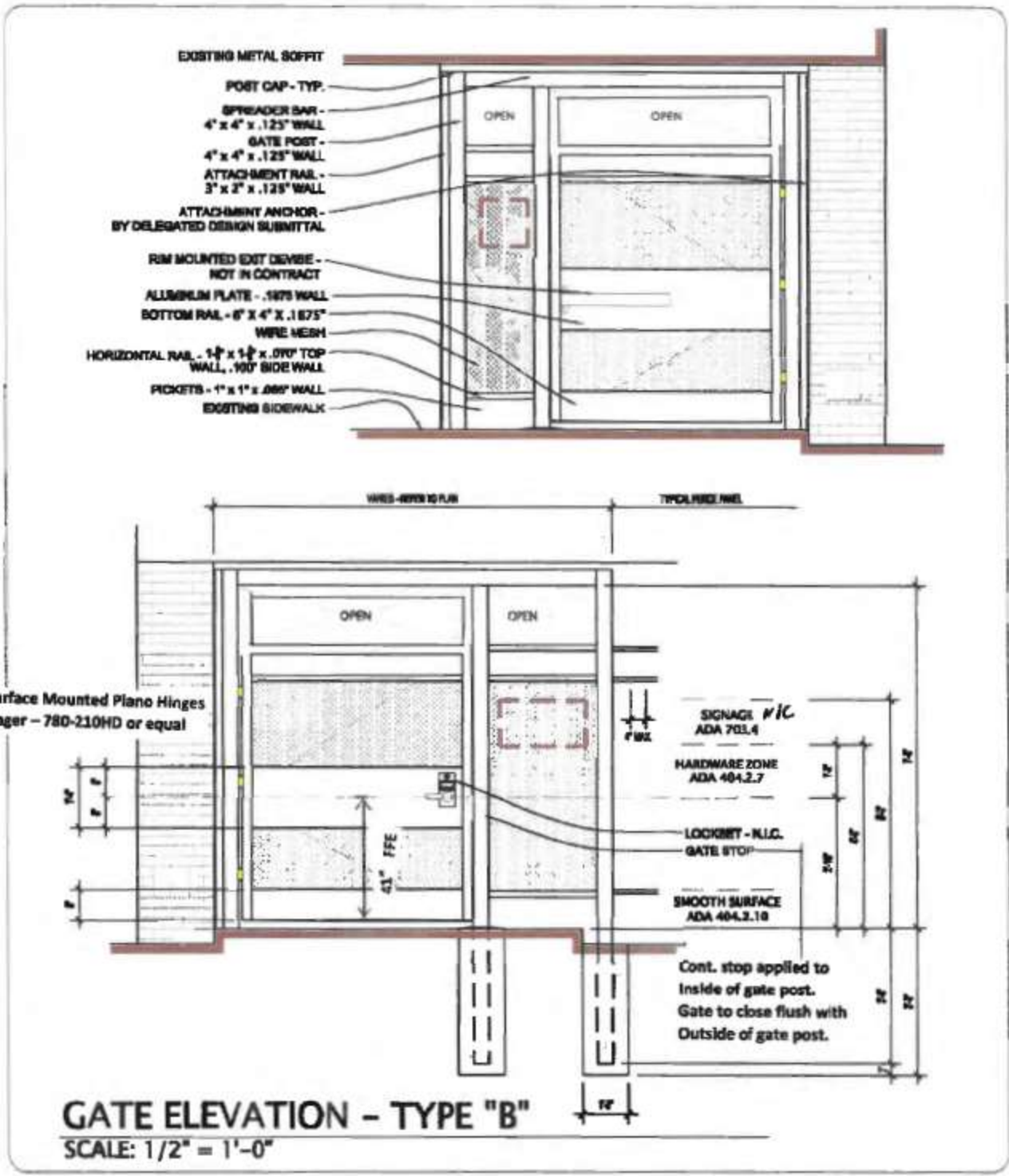

FENCING MATERIALS AND
INSTALLATION DISTRICT WIDE

LEON COUNTY SCHOOL BOARD
FACILITIES & CONSTRUCTION
3420 WEST THARPE STREET
TALLAHASSEE, FLORIDA 32303
(888) 617-6800

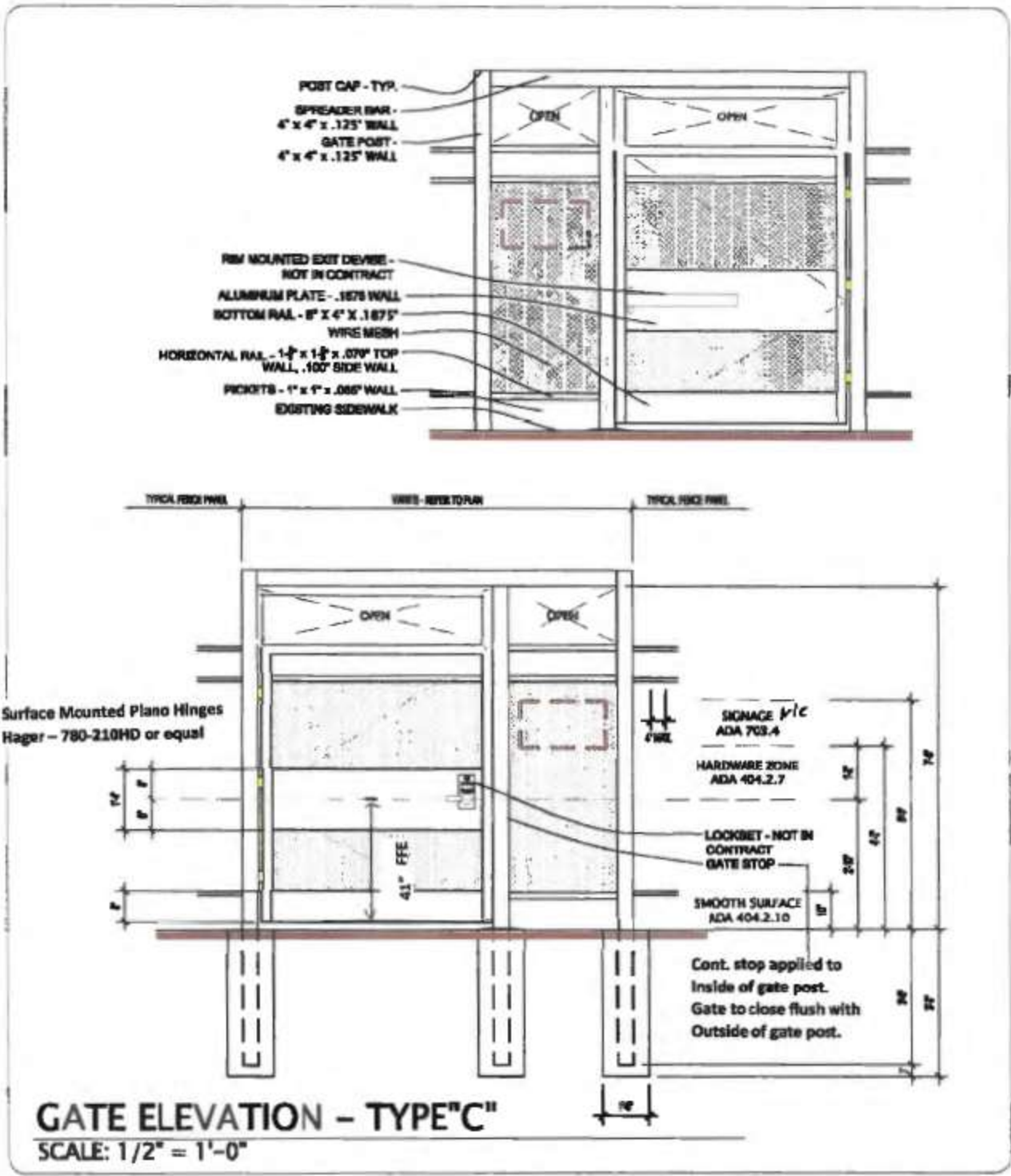

**FENCING MATERIALS AND
 INSTALLATION DISTRICT**

**LEON COUNTY SCHOOL BOARD
 FACILITIES & CONSTRUCTION
 3420 WEST THARPE STREET
 TALLAHASSEE, FLORIDA 32303
 (850) 817-5800**

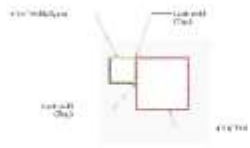

07 Frame Section B-B

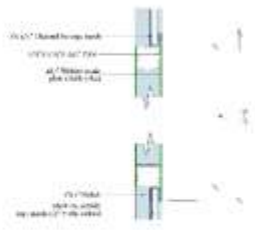

08 Door Section A-A

09 General Notes

- 1) General Notes: 3 sections of gate design - (A, B, C) Detailed section to be provided with ACS.
- 2) Complete hardware per LCS.
- 3) Call to - After appropriate procurement, all frame members are to be zinc and powder coating that be applied meeting or exceeding the following in order:
 - SSMA ACS Spec 100, 1st
 - SSMA ACS Spec 100, 2nd
 - SSMA ACS Spec 100, 3rd
 - SSMA ACS Spec 100, 4th
- 4) See loading elements of gate very per school campus and site context - door has with LCS.
- 5) Also note:
 - The gate will have a finish of all aluminum elements, or other metal and finish of the appropriate powder coating to meet above - this subject matter to be revised to be in Title Page (see 2022) as provided by "Buy" Submittal Sheet" and include at 1.5" as required by manufacturer.

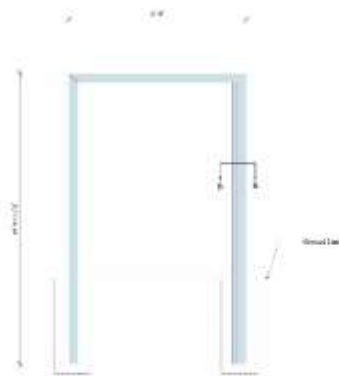

06 Header Frame - C

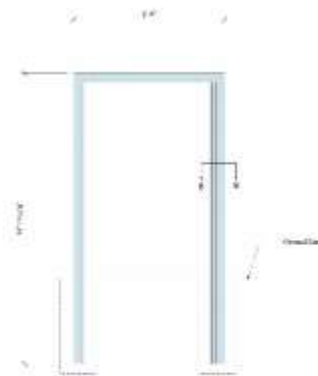

05 Header Frame - B

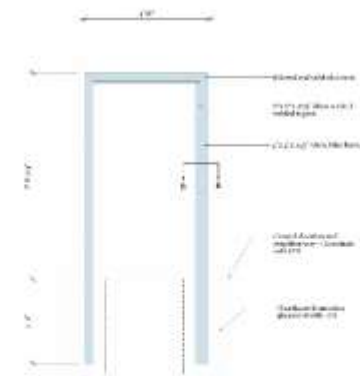

04 Header Frame - A

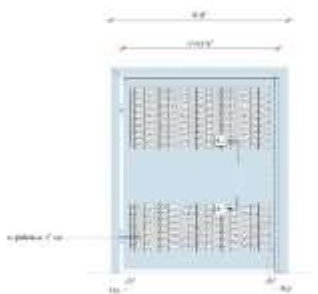

03 Door end Frame Inside View - C

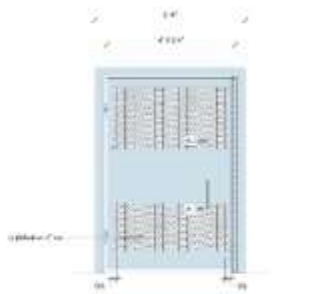

02 Door and Frame Inside View - B

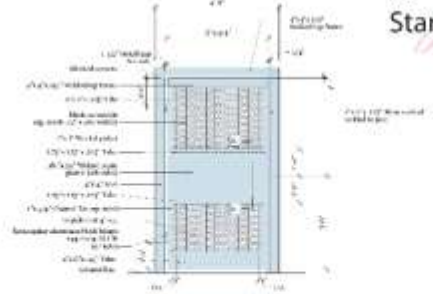

01 Door and Frame Inside View - A

James M Stark III
 Digitally signed by James M Stark III
 Date: 2021.06.28 15:18:33 -0400



LEON COUNTY SCHOOLS
 CAMPUS GATE

Standard Gate

LCS-1

STATE OF FLORIDA
 REGISTERED ARCHITECT

FILED	FILED
CHIEF	CHIEF
CLERK	CLERK
CLERK	CLERK
CLERK	CLERK